



Doc Title: Berth 2 Watermain Realignment and Replacement  
Doc Ref #: LET-VFPA-0008  
Doc Rev #: 0

Neptune Bulk Terminals Canada Ltd.  
Jurgen Franke, Director, Engineering and Projects  
1001 Low Level Road  
North Vancouver, BC, Canada V7L 1A7

July 14, 2023

Vancouver Fraser Port Authority, Project and Environmental Review  
Taisha Mitchell, RPBio, PAg, Environmental Specialist  
100 The Pointe, 999 Canada Place  
Vancouver, BC, V6C 3T4  
taisha.mitchell@portvancouver.com

re: Berth 2 Watermain Realignment and Replacement

---

Dear Taisha,

## 1 INTRODUCTION

Neptune Bulk Terminals (Canada) Ltd. (NBT) is undertaking the B2 Shiploader Project (B2 Project) which is considered a maintenance works project to upgrade the berth to accommodate ongoing operations. The B2 Project will replace the current B2 shiploader system and will consist of a new single traveling slewing potash shiploader, marine structures, and approach conveyors to replace the existing quadrant style West potash shiploader and East potash shiploader. The B2 Project consists of NBT and Vancouver Fraser Port Authority (the Port Authority) assets, where the combi-wall, owned by the Port Authority, is planned for replacement. A detailed description of the B2 Project scope is provided in Section 1.3.1 of the B2 Construction Environmental Management Plan (CEMP) (NBT, 2023b).

This letter supports the details on the temporary and permanent watermain design works that will be a component of the B2 Project.

## 2 WATERMAIN CONSTRUCTION

Temporary and permanent components of the watermain design were supported by R.F Binnie & Associates Ltd. (Binnie) (see Table 2-1, Appendix A). Construction activities will all be undertaken on land and will consist of a temporary and permanent components (see Table 2-2).

To support construction of the sheet pile wall, the existing watermain will need to be realigned temporarily during the construction phase of the B2 Project. Subsequent to construction, and prior to the B2 operational phase, the



watermain will be permanently reinstated. Drawing 2-1 is a general arrangement drawing that depicts, the existing, temporary and permanent reinstatement locations for the watermain as below:

- Existing alignment – red line.
- Temporary alignment – pink line.
- Permanent alignment – green line.

The objective of the temporary alignment is to circumvent the B2 Project footprint to allow for greater flexibility in construction sequencing, and thus it runs under the railway line around the existing store building (a component of B2 Project demolition) and back into the existing watermain. Subsequent to construction, the watermain will be permanently reinstated.

**Table 2-1: Watermain Design Drawings**

DRAWING NO	DRAWING TITLE
23-0747-GA-002	Civil Underground Utilities - General Notes
22-0747-UT-010	Civil Underground Utilities – Existing Site Plan
22-0747-UT-020	Civil Underground Utilities – Existing Removals
22-0747-UT-101	Civil Underground Utilities – Watermain General Arrangement
22-0747-UT-110	Civil Underground Utilities – Watermain Plan & Profile – Sheet 1
22-0747-UT-111	Civil Underground Utilities – Watermain Plan & Profile – Sheet 2
22-0747-UT-150	Civil Underground Utilities – Watermain Typical Details– Sheet 1
22-0747-UT-152	Civil Underground Utilities – Watermain Plan & Profile – Sheet 2

**Table 2-2: Watermain Construction Activities Summary**

TITLE	CONSTRUCTION SUMMARY	
	TEMPORARY	PERMANENT
Activity No. in Table 3-2 of B2D2 CEMP	4A	20
Construction Description	To allow for the construction of B2, it is necessitated that the existing watermain is cut and removed to facilitate the construction of the sheet pile wall for the B2 Project. A temporary watermain will be re-routed around the B2 Project area, under the railway line/temporary road, around the existing stores building, and back into the existing watermain. The temporary	Following construction, a permanent watermain will be installed through the B2 area with the addition of various water connection points and an additional hydrant added. The temporary watermain will be capped and abandoned.



TITLE	CONSTRUCTION SUMMARY	
	TEMPORARY	PERMANENT
	watermain alignment will go around the existing stores building in the eastern portion to allow the greatest flexibility for construction sequencing. One hydrant in the B2 area will be removed and relocated outside of the construction area.	
Activity Schedule	Four weeks, July to August 2025	4 weeks, January to February 2027

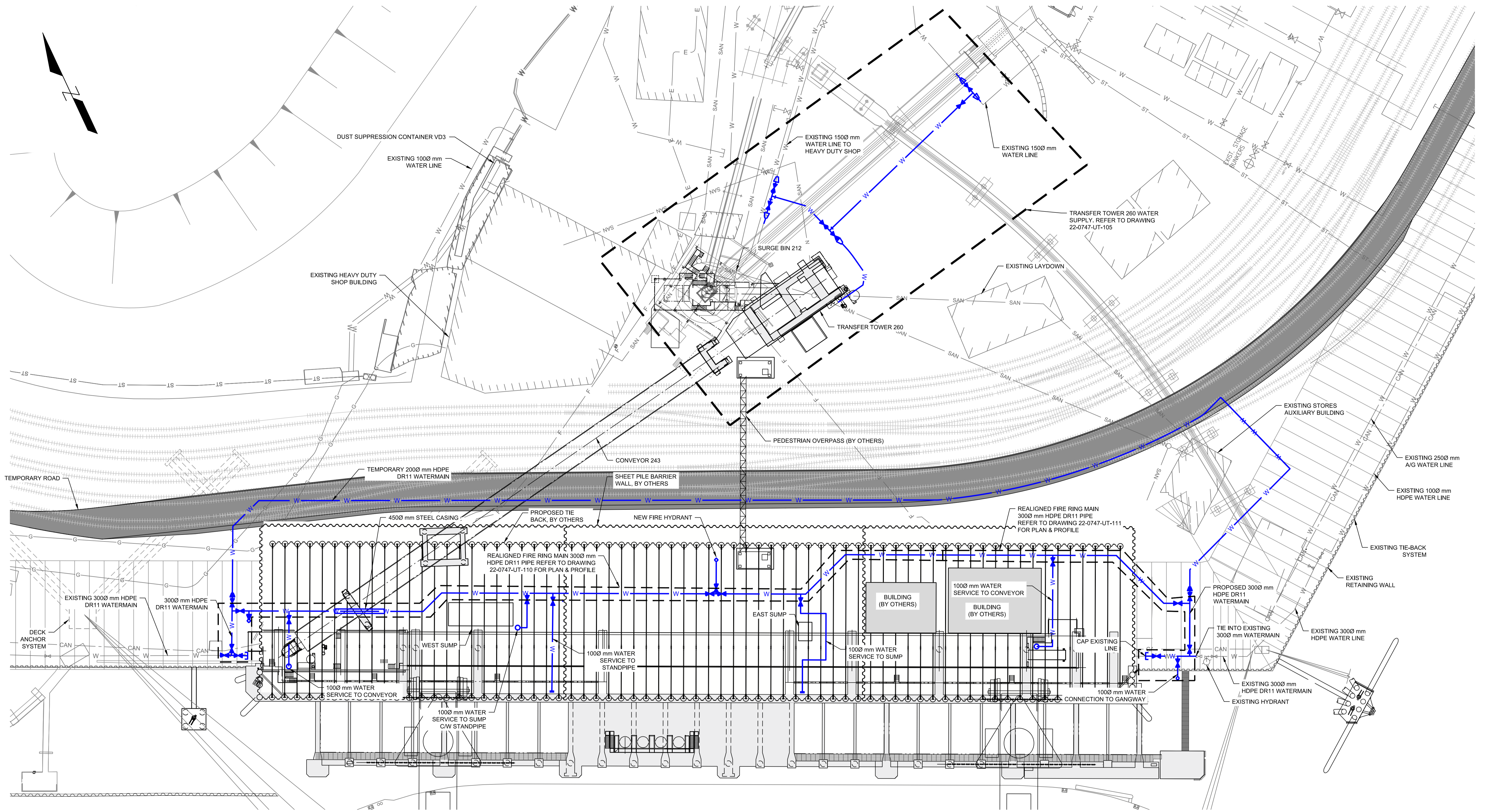

**PROPOSED WATERMAIN PLAN VIEW**

SCALE: 1:400

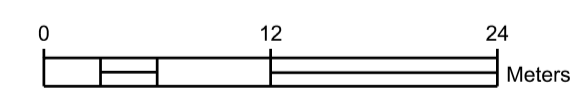

**LEGEND:**

- W — PROPOSED WATERMAIN
- G — EXISTING GAS PIPE
- - - CAN - - - EXISTING CANOLA OIL PIPE (ABANDONED)
- W — EXISTING WATERMAIN
- E — EXISTING ELECTRICAL CONDUIT
- SAN — EXISTING SANITARY PIPE
- ST — EXISTING DRAINAGE LINE
- S — EXISTING SUMP
- F — EFFLUENT LINE
- V — EXISTING VALVE
- H — EXISTING HYDRANT

PROJECT:	TBD
SYSTEM:	TBD
ASSET:	TBD
DISCIPLINE:	CIVIL

A	2023-06-09	ISSUED FOR REVIEW	JK	CV
REV	YYYY-MM-DD	DESCRIPTION	DRAWN	APPROVED
ISSUES / REVISIONS				

ENGINEERING SEAL:  
VENDOR P2P:

VENDOR: **BINNIE**

OEM:

ISSUED AS RECORD COPY? (YES/NO) NO

**Neptune TERMINALS**

THIS DRAWING IS THE PROPERTY OF NEPTUNE BULK TERMINALS (CANADA) LTD. NEITHER THIS DRAWING NOR ANY PORTION THEREOF SHALL BE REPRODUCED WITHOUT WRITTEN PERMISSION FROM NEPTUNE BULK TERMINALS (CANADA) LTD.

TITLE: <b>BERTH 2 SHIPLOADER PROJECT - CIVIL UNDERGROUND UTILITIES - WATERMAIN GENERAL ARRANGEMENT</b>			
SCALE: AS SHOWN	SHEET OF 5 13	DRAWING NO. 22-0747-UT-101	REV: A

P:\2022\22-0747\101 - CAD FILE\ESID\DWG\ENAL\22-0747-UT-101.DWG DATE: 2023-05-30



Doc Title: Berth 2 Watermain Realignment and Replacement  
Doc Ref #: LET-VFPA-0008  
Doc Rev #: 0

### 3 CLOSURE

We appreciate your time in reviewing this letter. Please reach out to Victoria with any further questions.

Sincerely,

A handwritten signature in black ink, appearing to read 'Victoria Burdett-Coutts', written over a light blue horizontal line.

Victoria Burdett-Coutts  
Senior Regulatory Professional  
Neptune Bulk Terminals  
(CANADA) Ltd.  
C: 778-839-2372  
[vburdett-coutts@neptuneterminals.com](mailto:vburdett-coutts@neptuneterminals.com)



Doc Title: Berth 2 Watermain Realignment and Replacement  
Doc Ref #: LET-VFPA-0008  
Doc Rev #: 0

## APPENDIX A: WATERMAIN UTILITIES DRAWING

**1.0 GENERAL NOTES**

- ALL WORKS SHALL BE CONSTRUCTED IN ACCORDANCE WITH THE GENERAL NOTES, SPECIFICATIONS AND DRAWINGS, IN ORDER OF PRECEDENCE.
  - AS DETAILED ON THE DRAWINGS
  - PROJECT-SPECIFIC TECHNICAL SPECIFICATIONS AND CONTRACT DOCUMENTS
  - GENERAL NOTES
  - NEPTUNE STANDARD DETAILS, DESIGN CRITERIA, AND SPECIFICATIONS
- ALL DIMENSIONS ARE IN METRIC UNITS UNLESS NOTED OTHERWISE.
- ALL EXISTING INFORMATION ON STRUCTURES, MONUMENTS, BURIED/UNDERGROUND SERVICES AND UTILITIES IS BASED ON AVAILABLE RECORDS AND SHALL NOT BE CONSTRUED TO BE COMPLETE OR ACCURATE. ALTHOUGH MEASURES HAVE BEEN TAKEN FOR COMPLETENESS AND ACCURACY, THE CONTRACTOR IS TO CONDUCT THE NECESSARY MEASURES TO CONFIRM ALL UNDERGROUND UTILITIES WITHIN THEIR WORK AREA.
- PRIOR TO CONSTRUCTION OF NEW WORKS, THE CONTRACTOR SHALL VERIFY THE EXACT LOCATION AND INVERT ELEVATION OF ALL EXISTING UNDERGROUND UTILITIES WITHIN THE WORK AREA BY METHOD OF HYDROVAC EXCAVATION, IN ADDITION TO VERIFYING DIMENSIONS OF ALL EXISTING STRUCTURES IN THE FIELD. THE CONTRACTOR IS TO NOTIFY THE ENGINEER OF ANY DISCREPANCIES, CONFLICTS, OMISSIONS, OR WHERE VARIATIONS IN DIMENSIONS / ELEVATIONS OF EXISTING STRUCTURES MAY AFFECT THE DESIGN INTEGRITY OF THE WORKS DESCRIBED ON THE DRAWINGS OR IN THE SPECIFICATIONS. THE CONTRACTOR IS REQUIRED TO CONTACT THE ENGINEER IMMEDIATELY PRIOR TO PROCEEDING WITH THE FABRICATIONS, INSTALLATION OR ERECTIONS OF THE ITEMS IN QUESTION.
- CONTRACTOR TO TAKE EXTREME CARE WHEN WORKING NEAR OR AROUND EXISTING SERVICES. ANY DISTURBANCE TO THESE SERVICES TO BE REPLACED OR MADE GOOD TO THE SATISFACTION OF NEPTUNE AND THE ENGINEER. NEPTUNE AND THE ENGINEER ARE TO BE NOTIFIED PRIOR TO DOING ANY REPAIRS, AND SHUTDOWN AND REPAIR OF EXISTING UNDERGROUND SERVICE IS TO BE DONE UNDER NEPTUNE SUPERVISION.
- UNLESS APPROVED BY THE ENGINEER AND NEPTUNE, ALL EXISTING UNDERGROUND SERVICES ARE TO BE MAINTAINED DURING CONSTRUCTION. WHEN A DISRUPTION TO SERVICES IS REQUIRED TO CARRY OUT THE WORK, THE CONTRACTOR IS REQUIRED TO PROVIDE THE ENGINEER A WORK PLAN A MINIMUM OF 2 WEEKS PRIOR TO THE DISRUPTION TO OUTLINE THE DURATION OF THE DISRUPTION AND THE WORK TO BE COMPLETED. ALL DISRUPTIONS ARE TO BE APPROVED BY NEPTUNE. MEANS OR REQUIREMENTS OF TEMPORARY SERVICE TO MINIMIZE THE DISRUPTION TO NEPTUNE TO BE INCLUDED IN THE CONTRACTORS METHODOLOGY.
- WARNING: DIRECT BURY ELECTRICAL CABLES & CONDUITS MAY NOT BE ACCURATELY SHOWN ON DRAWINGS, CONFIRM WITH THE ENGINEER PRIOR TO EXCAVATION WORK.
- ALL EXISTING UTILITIES ARE SHOWN SCHEMATICALLY OR PSEUDO-SCHEMATICALLY WITH ALIGNMENTS AND LOCATIONS OF UTILITY STRUCTURE POTENTIALLY SHIFTED FOR CLARITY.
- THE CONTRACTOR IS TO ENSURE THAT ALL APPROVALS REQUIRED FOR THE PROPOSED WORKS HAVE BEEN OBTAINED FROM ALL AUTHORITIES AND AGENCIES PRIOR TO COMMENCEMENT OF WORK.
- CONTRACTOR TO SUBMIT SHOP DRAWINGS FOR FABRICATED ITEMS AND APPROVAL DRAWINGS FOR ALL EQUIPMENT PRIOR TO FABRICATION OR ORDERING, RESPECTIVELY.
- TEMPORARY WATER CONNECTIONS: ALL TEMPORARY WATER CONNECTIONS SHALL INCLUDE AN RPBA PRIOR TO CONNECTION TO ANY CONTRACTOR SYSTEMS OR HOSES.
- ALL TEMPORARY CONNECTIONS ARE TO MEET NSF APPROVED PIPE (HDPE, PE, ETC.) PRIOR TO THE RPBA.
- THE CONTRACTOR SHALL BE RESPONSIBLE FOR FREEZE PROTECTION OF ANY OF THEIR TEMPORARY WATER CONNECTIONS.
- CONTRACTORS USING THE FIRE HYDRANTS ARE TO INSTALL A MANUAL CONTROL VALVE AND RPBA ON THE HYDRANT. THE HYDRANT IS TO BE OPERATED EITHER FULLY OPEN OR FULLY CLOSED. THE FIRE HYDRANT IS NOT TO BE USED TO MANUALLY ADJUST FLOW SINCE THE DRAIN VALVE AT THE BOTTOM OF THE HYDRANT WILL BE ENGAGED. WHEN NOT IN USE, THE HYDRANT IS TO BE CLOSED. THE CONTRACTOR SHALL BE RESPONSIBLE TO REPAIR OR REPLACE THE FIRE HYDRANT SHOULD ANY OF THEIR USE CAUSE DAMAGE TO IT.

**2.0 SURVEY**

- ALL PLANS ARE IN THE LOCAL NEPTUNE GROUND-LEVEL COORDINATE SYSTEM. TO CONVERT GROUND LEVEL NBTC COORDINATES TO ZONE 10, NAD83 CSRS UTM COORDINATES, ADD 2172.427 TO NORTHING AND 197.590 TO EASTING, THEN MULTIPLY 0.99960240 (COMBINED SCALE FACTOR) ABOUT 0.0 ORIGIN.
- ELEVATIONS ARE IN METERS AND ARE REFERRED TO GEODETIC DATUM CVD28GVRD USING MONUMENT NBTC9, ELEVATION 3.679 METERS.
- AFTER CONSULTATION WITH THE ENGINEER, THE CONTRACTOR SHALL ESTABLISH SUITABLE MONUMENTATION TO SERVE AS TEMPORARY SURVEY CONTROL FOR THE CONSTRUCTION OF THEIR WORKS. THE TEMPORARY SURVEY CONTROL SHALL BE LOCATED IN THE GENERAL VICINITY OF THE CONTRACTOR WORK AREA BUT NOT IN AREAS THAT WILL INTERFERE WITH SITE OPERATIONS.
- THE CONTRACTOR IS RESPONSIBLE FOR MAINTAINING ACCURATE POSITION AND LEVEL CONTROL FOR THE DURATION OF THEIR CONSTRUCTION WORKS.
- THE CONTRACTOR SHALL PERFORM SUFFICIENT CHECKS ON THEIR TEMPORARY SURVEY CONTROL USING THE ESTABLISHED SITE SURVEY CONTROL POINTS. MINIMUM FREQUENCY IS ONCE EVERY TWO WEEKS OR WHEN CONTROL IS DAMAGED OR AFFECTED BY THE WORK.
- THE CONTRACTOR SHALL MAINTAIN RECORDS OF THEIR CONTROL CHECKS AND HAVE IT AVAILABLE AT ALL TIMES FOR THE ENGINEER TO AUDIT. THE RECORDS SHALL CONTAIN, AT A MINIMUM, DATES, TIMES, NORTHINGS, EASTINGS, ELEVATIONS, ACCURACY, AND BUSTS. THE DATA SHALL BE PRESENTED IN METRIC UNITS. THE DATA WILL BE ORGANIZED SUCH THAT DATA WILL BE ADDED TO FROM THE START OF THE WORK UNTIL IT IS COMPLETE.

**3.0 UNDERGROUND SERVICES**

- ALL CONSTRUCTION PRACTICES AND MATERIALS TO BE IN ACCORDANCE WITH:
  - THE MASTER MUNICIPAL CONSTRUCTION DOCUMENTS - STANDARD DETAIL DRAWINGS (MMCD), LATEST EDITION.
  - NEPTUNE DESIGN AND CONSTRUCTION STANDARDS, AND;
  - APPLICABLE CONTRACT DOCUMENTS AND ALL SPECIFICATIONS REFERENCED THEREIN
- CONTRACTOR TO MAINTAIN ON SITE COPIES OF THE ABOVE DOCUMENTS AND TO ENSURE THAT ALL TRADES ARE THOROUGHLY FAMILIAR WITH THE APPLICABLE SECTIONS OF THESE DOCUMENTS.
- INSTALLATION AND TESTING OF PIPES TO BE COMPLETED IN ACCORDANCE WITH THE CONTRACT SPECIFICATIONS FOR EACH SPECIFIC UTILITY.
- CONTRACTOR TO SUPPLY ALL MATERIALS NECESSARY FOR A COMPLETE AND WORKING INSTALLATION. WHERE DETAILS ARE NOT EXPLICIT, CONTRACTOR TO NOTIFY THE ENGINEER.
- CONTRACTOR IS TO REMOVE ALL EXISTING UNDERGROUND UTILITIES INDICATED ON THE DRAWINGS OR OTHERWISE NO LONGER IN USE. IF UTILITY IS UNABLE TO BE REMOVED, CONTRACTOR TO NOTIFY THE ENGINEER OR DECOMMISSION IN A MANNER SHOWN ON THE DETAILED DRAWINGS. THE ENGINEER AND NEPTUNE ARE TO BE NOTIFIED PRIOR TO REMOVING OR DECOMMISSIONING EXISTING UTILITIES. WHERE POSSIBLE, CONTRACTOR MAY RE-USE EXISTING MATERIALS APPROVED BY THE ENGINEER.
- ALL UNDERGROUND UTILITIES WITHIN 5.0m OF PILING WORKS ARE TO BE ASSESSED FOR SETTLEMENT AND MIS-ALIGNMENT. CONTRACTORS SHALL PROVIDE DETAILED REPORTS TO THE ENGINEER FOR REVIEW & RECORD, AND ALL PIPES SHALL BE REPAIRED TO THE SATISFACTION OF THE ENGINEER.
  - ALL SANITARY & STORM GRAVITY SYSTEM PIPES ARE TO BE INSPECTED POST-PILING VIA CLOSED-CIRCUIT TELEVISION (CCTV).
  - ALL PRESSURIZED SYSTEMS (WATERMAIN, FORCEMAIN) PIPES ARE TO BE INSPECTED POST-PILING VIA A COMBINATION OF CLOSED-CIRCUIT TELEVISION (CCTV) & ACOUSTIC-LEAK DETECTION.

**4.0 EXCAVATING, TRENCHING, AND BACKFILLING**

- TRENCHING, BACKFILL, AND COMPACTION REQUIREMENTS SHALL BE PERFORMED IN ACCORDANCE WITH THE CONTRACT SPECIFICATIONS.
- CONTRACTOR SHALL SAWCUT OR MILL, REMOVE AND DISPOSE OF ANY ASPHALT MATERIALS OFFSITE. ALL ASPHALT CUTS SHALL BE STRAIGHT WITH VERTICAL CLEAN EDGES SUCH THAT THE ASPHALT SURFACE MAY BREAK EVENLY AND CLEANLY.
- CONTRACTOR SHALL EXCAVATE AND STOCKPILE MATERIALS AS REQUIRED OR AS DIRECTED BY THE ENGINEER OR NEPTUNE. FOR MATERIALS TO BE DISPOSED OF OFFSITE, CONTRACTOR SHALL BE RESPONSIBLE FOR ALL ENVIRONMENTAL TESTING. ONCE MATERIAL IS TESTED AND CHARACTERIZED, THE CONTRACTOR SHALL DISPOSE OF MATERIAL OFFSITE TO A CERTIFIED DUMP SITE.
- TRENCHING IN EXISTING PAVED ROADWAYS SHALL BE EXCAVATED VERTICALLY WITH THE USE OF SHORE BOXES, IF REQUIRED, TO MINIMIZE EXCAVATION FOOTPRINT.
- OPEN TRENCHES IN EXISTING PAVED ROADWAYS ARE NOT TO BE LEFT OPEN AT THE END OF SHIFT. CONTRACTOR WILL BE REQUIRED TO BACKFILL TO SURFACE OR PLACE ROAD PLATES AT END OF DAY. TRENCHES MAY BE LEFT OPEN ONLY UPON THE APPROVAL OF THE ENGINEER AND NEPTUNE.
- CONTRACTOR TO RE-USE APPROVED EXCAVATED MATERIAL FOR BACKFILL AS DIRECTED BY THE ENGINEER. IF ANY MATERIAL IS UNSUITABLE, ENGINEER IS TO BE NOTIFIED IMMEDIATELY.
- COMPACTION TESTING IS TO BE PERFORMED IN ACCORDANCE WITH CONTRACT QUALITY CONTROL PROGRAM AND CONTRACT SPECIFICATIONS.
- QUALITY CONTROL INFORMATION SHALL BE RECORDED FOR ALL COMPACTION AND SOIL TESTING, PASS AND FAILS. COPIES OF THE TESTING TO BE DOCUMENTED IN THE QUALITY CONTROL PLAN WITH A HARD COPY LOCATED AT SITE FOR THE DURATION OF THE PROJECT, FOR REVIEW BY THE ENGINEER. A DIGITAL COPY OF ALL TESTING IS TO BE PROVIDED AT THE END OF THE PROJECT.

**5.0 SURFACE RESTORATION / HMAC PAVING**

- SURFACE RESTORATION TO BE COMPLETED ON ALL TRENCHING THROUGH PAVED AREAS OF THE SITE.
- HOT MIX ASPHALTIC CEMENT (HMAC) AND GRANULAR MATERIALS SHALL BE SUPPLIED AND INSTALLED IN ACCORDANCE WITH THE GENERAL NOTES, SPECIFICATIONS AND CONTRACT DOCUMENTS.
- PAVEMENT STRUCTURE CONFORM TO DRAWING DETAILS OR MATCH EXISTING PAVEMENT STRUCTURE GRAVEL AND HMAC THICKNESS, WHICHEVER IS MORE STRINGENT.
- TRENCHING IN PAVED AREAS OR ROADWAYS SHALL HAVE THE PAVEMENT REINSTATED ONCE THE TRENCH IS FULLY BACKFILLED AND THE WORK IS COMPLETE.

**6.0 WATER**

- ALL WATER WORKS ARE TO BE COMPLETED IN ACCORDANCE WITH THE PROJECT SPECIFICATIONS AND CONSTRUCTION DRAWING DETAILS, INCLUDING INSTALLATION, TESTING, & CLEANING (CHLORINATION).
- ALL UNDERGROUND WATERMAIN PIPE IS:
  - HIGH DENSITY POLYETHYLENE (HDPE) DR11, PE4710 PR, TYPICAL U.N.O.
  - DUCTILE IRON (DI) CEMENT MORTAR LINED PIPE, PRESSURE CLASS 350, AS/WHERE NOTED.
  - POLYVINYL CHLORIDE (PVC), C900 CLASS 200 (DR14) TO AWWA C900, CERTIFIED TO CSA B137.3, AS/WHERE NOTED.
- WATER SERVICE PIPE TO BE IPEX Q-LINE WATER SERVICE TUBING RATED FOR 200 PSI SERVICE.
- FITTINGS ARE DUCTILE IRON FITTINGS TO AWWA C110, SUITABLE FOR PRESSURE RATING 2415 kPa, & CEMENT MOTOR LINED TO AWWA C104, OR HDPE MITERED FITTINGS TO AWWA C906, RATED TO MATCH PIPE PRESSURE RATING, OR HDPE MOLDED FITTINGS TO ASTM D3261, RATED TO MATCH PIPE PRESSURE RATING. CONTRACTOR TO CONFIRM WITH THE ENGINEER PRIOR TO USE.

- HIGH-DENSITY POLYETHYLENE PIPE JOINTS:
  - JOINTS SHALL BE FLANGED, BUTT-FUSED, OR JOINED VIA ELECTROFUSION COUPLER, AS INDICATED ON THE DRAWINGS. ALL JOINTS SHALL BE RESTRAINED.
- DUCTILE IRON PIPE JOINTS:
  - JOINTS SHALL BE BELL-AND-SPIGOT, MECHANICAL JOINTS, OR TR FLEX JOINTS, TO AWWA C111, AS INDICATED ON THE DRAWINGS. ALL JOINTS SHALL BE RESTRAINED.
  - UNRESTRAINED (BELL-AND-SPIGOT) JOINTS, FITTINGS AND DEAD ENDS (HYDRANTS, END CAPS) ARE TO BE MECHANICALLY RESTRAINED VIA INSTALLATION OF THRUST BLOCKS AND JOINT RESTRAINTS.
  - ALL DUCTILE IRON PIPE SHALL WRAPPED WITH LINEAR LOW-DENSITY POLYETHYLENE (LLDPE) BAGS, 8 MILS THICK PER AWWA C105/A21.5.
- POLYVINYL CHLORIDE PIPE JOINTS:
  - JOINTS SHALL BE PUSH-ON, INTEGRALLY THICKENED BELL & SPIGOT TYPE TO ASTM D3139 WITH ELASTOMERIC GASKETS TO ASTM F477.
  - ALL JOINTS, FITTINGS AND DEAD ENDS (HYDRANTS, END CAPS) ARE TO BE MECHANICALLY RESTRAINED VIA INSTALLATION OF THRUST BLOCKS AND JOINT RESTRAINTS
- INSTALLATION OF HDPE PIPE: IN ACCORDANCE WITH ASTM D2774, MANUFACTURERS RECOMMENDATIONS, AND APPLICABLE CONTRACT SPECIFICATIONS:
  - JOIN PIPE AND FITTINGS INTO CONTINUOUS LENGTHS ON THE JOB SITE, ABOVE GROUND, IN LAY DOWN AREAS AVAILABLE TO THE CONTRACTOR.
  - UNLESS OTHERWISE INDICATED, JOIN PIPES BY THE BUTT FUSION OR ELECTRO FUSION METHOD PERFORMED IN ACCORDANCE WITH THE PIPE MANUFACTURER'S RECOMMENDATIONS AND ASTM F2620 OR ASTM F1055.
  - DO NOT USE SOCKET FUSION, EXTRUSION WELDING OR HOT GAS WELDING.
  - BUTT FUSION EQUIPMENT USED IN JOINING PROCEDURES SHALL BE CAPABLE OF MEETING ALL CONDITIONS RECOMMENDED BY THE PIPE MANUFACTURER.
  - BUTT FUSION JOINING SHALL PRODUCE A JOINT WELD STRENGTH EQUAL TO OR GREATER THAN THE TENSILE STRENGTH OF THE PIPE ITSELF.
  - FACTORY FABRICATED FITTING ADAPTORS, ASSEMBLIES, OR A COMBINATION OF THERMAL BUTT-FUSION AND ADAPTER ASSEMBLIES SHALL BE ALLOWED FOR BENDS, IN ACCORDANCE WITH MANUFACTURER'S REQUIREMENTS.
  - A MAXIMUM MISALIGNMENT OF 10% OF THE WALL THICKNESS IS ACCEPTABLE.
  - CONSULT THE PIPE SUPPLIER TO OBTAIN MACHINERY AND EXPERTISE FOR THE JOINING BY BUTT FUSION OF HDPE PIPE AND FITTINGS. NO PIPE OR FITTINGS SHALL BE JOINED BY FUSION BY ANY OF THE CONTRACTOR'S PERSONNEL UNLESS THEY ARE QUALIFIED IN THE TECHNIQUES INVOLVED.
  - QUALITY CONTROL INFORMATION SHALL BE RECORDED FOR EACH JOINT, INCLUDING JOINT NUMBER, OPERATOR, FUSE TEMPERATURE, PRESSURE AND TIME.
- INSTALLATION OF DUCTILE IRON PIPE: IN ACCORDANCE WITH AWWA C600 & C151, MANUFACTURER'S RECOMMENDATIONS AND APPLICABLE CONTRACT SPECIFICATIONS.
  - JOINT DEFLECTIONS DO NOT EXCEED ONE-HALF MAXIMUM JOINT DEFLECTION SPECIFIED IN AWWA C600 NOR ONE-HALF MAXIMUM JOINT DEFLECTION RECOMMENDED BY PIPE MANUFACTURER.
  - INSTALLATION OF PVC PIPE: IN ACCORDANCE WITH AWWA M23, MANUFACTURER'S RECOMMENDATIONS AND APPLICABLE CONTRACT SPECIFICATIONS AND PER FOLLOWING:
    - MAXIMUM JOINT DEFLECTION SHOULD NOT EXCEED ONE-HALF OF THE MANUFACTURER'S RECOMMENDED SPECIFICATION FOR PVC PIPE.
    - PIPE SHALL NOT BE INSTALLED WITH A RADIUS. SHOULD IT BE DETERMINED THE PIPE IS INSTALLED WITH A RADIUS, THE CONTRACTOR WILL BE REQUIRED TO EXCAVATE AND REINSTALL THE PIPE AT THEIR COST.
- INSTALLATION OF BURIED FITTINGS:
  - FITTINGS SHALL INCLUDE CATHODIC PROTECTION AS OUTLINED IN THE SPECIFICATIONS.
  - ALL BURIED FITTINGS, BOLTS, NUTS, WASHERS, ETC. SHALL BE WRAPPED IN PETROLATUM TAPE IN ACCORDANCE WITH AWWA C217 AND NACE SP0375.
  - ALL BURIED FLANGED FITTINGS AND CONNECTIONS TO USE GALVANIZED STEEL BOLTS, NUTS AND WASHERS.
  - ALL HDPE BACKER RINGS TO BE HOT DIPPED GALVANIZED DUCTILE IRON TO ASTM A536.
  - FOR HDPE WATER MAIN, ALL BOLTED CONNECTIONS TO BE LEFT EXPOSED UNTIL PRESSURE TESTS ARE PERFORMED. ONCE PRESSURE HAS BEEN RELEASED, BOLTED CONNECTIONS ARE TO BE RE-TORQUED TO FINAL TARGET TORQUE VALVES AND JOINTS PRIOR TO BEING WRAPPED IN PETROLATUM TAPE. IF RE-TORQUING IS NOT PERFORMED, THE JOINT WILL CREEP AND BEGIN TO LEAK. SHOULD THIS OCCUR, THE CONTRACTOR WILL BE RESPONSIBLE FOR RE-EXCAVATING AND REPAIRING THE LEAK AT THEIR COST.
  - PERFORMED, THE JOINT WILL CREEP AND BEGIN TO LEAK. SHOULD THIS OCCUR, THE CONTRACTOR WILL BE RESPONSIBLE FOR RE-EXCAVATING AND REPAIRING THE LEAK AT THEIR COST.
- PRESSURE AND LEAKAGE TESTING TO BE CARRIED OUT BY A CERTIFIED THIRD PARTY TESTING AGENCY OR CONTRACTOR, IN ACCORDANCE WITH THE CONTRACT SPECIFICATIONS AND AS PER ASTM F2164.
- FLUSHING AND DISINFECTION TO BE PERFORMED IN ACCORDANCE WITH THE CONTRACT SPECIFICATIONS AND AWWA C651.
- CONTRACTOR TO PERFORM ALL TESTS IN THE PRESENCE OF THE ENGINEER AND IS TO PROVIDE A MINIMUM OF 24 HOURS NOTICE IN ADVANCE OF A PROPOSED LEAKAGE TEST. CONTRACTOR TO FILL THE PIPES AND LET REST FOR A MINIMUM OF 24 HOURS PRIOR TO PRETESTING / TESTING.
- CONTRACTORS MATERIALS AND TEST CERTIFICATE FOR UNDERGROUND PIPING IS TO BE PROVIDED UPON COMPLETION OF ALL WATER MAIN WORKS. TESTING DOCUMENTS / CERTIFICATES VERIFYING THE PRESSURE AND DISINFECTIONS TESTS WERE COMPLETED AND PASSED, ARE TO BE PROVIDED PRIOR TO FINAL TIE-INS TO EXISTING MAINS.
- PROTECTION OF THE WATER MAIN - SEPARATION FROM SEWERS:
  - PARALLEL LINES: WATER MAINS SHOULD BE LAID AT LEAST 3.0m HORIZONTALLY FROM ANY SANITARY OR STORM SEWER. WHERE THIS HORIZONTAL SEPARATION IS NOT POSSIBLE, THE BOTTOM OF THE WATER MAIN SHOULD BE AT LEAST 0.45m ABOVE THE TOP OF THE SEWER AND SUFFICIENTLY TO ONE SIDE OF THE SEWER TO ALLOW FOR SEWER REPAIRS WITHOUT DISTURBING THE WATER MAIN. IF THIS VERTICAL SEPARATION IS NOT POSSIBLE, THE SEWER SHOULD BE ON THE SAME SERVICE CAPABILITY AS THE WATER MAIN WITH PRESSURE CLASS JOINTS DESIGNED TO REMAIN WATERTIGHT IF THE GROUNDWATER TABLE PERIODICALLY RISES ABOVE THE

- SEWER AND MUST BE PRESSURE TESTED BEFORE BACKFILLING. OTHER PRECAUTIONS, SUCH AS A WATER MAIN WITH IMPROVED JOINTS AND HIGHER STRENGTH MAY BE NEEDED.
- CROSSINGS: WHERE A WATER MAIN CROSSES A SANITARY OR STORM SEWER, THE LINES SHOULD BE LAID WITH THE WATER MAIN CROSSING OVER THE SEWER AND WITH THE MIDDLE OF PIPE LENGTHS LOCATED AT THE CROSSING POINT TO MAXIMIZE THE SEPARATION BETWEEN JOINTS WHERE A MINIMUM 3.0m JOINT SEPARATION AND/OR A MINIMUM 0.45m CLEAR VERTICAL SEPARATION IS NOT POSSIBLE AT THE CROSSING. PRECAUTIONS TO IMPROVE WATER TIGHTNESS OF THE SEWER JOINTS AND STRUCTURAL IMPROVEMENTS SUCH AS HIGHER STRENGTH WATER MAIN AND/OR SEWER AT THE CROSSING AREA MAY BE NEEDED. SLEEVEING, PIPE BRIDGING OR OTHER SUITABLE MEASURES MAY BE CONSIDERED. ALL JOINTS WITHIN 3.0m OF THE CROSSING SHOULD BE HEAT SHRINK WRAPPED WITH CANUSA AQUA-SHIELD SLEEVES, AWWA C216.
  - WHEN THE WATER MAIN IS CLOSER THAN 300mm TO A STORM SANITARY OR EFFLUENT SEWER, THE WATER LINE MUST BE LAID IN SUCH A MANNER THAT CROSSING IS MADE MIDWAY BETWEEN JOINTS ON A FULL LENGTH OF WATER MAIN. THE MAIN JOINTS ARE TO BE WRAPPED WITH HEAT SHRINK PLASTIC OR PACK WITH COMPOUND AND WRAPPED WITH TAPE OVER A LENGTH EXTENDING 3.0m ON EITHER SIDES OF THE SEWER MAIN.
  - WHEN 10' HORIZONTAL SEPARATION BETWEEN THE WATER MAINS AND STORM SANITARY OR EFFLUENT SEWERS IS UNATTAINABLE, ALL WATER MAIN JOINTS ARE TO BE WRAPPED WITH HEAT SHRINK PLASTIC PACKED WITH COMPOUND AND WRAPPED WITH TAPE

**7.0 SANITARY**

- ALL SANITARY FORCEMAIN & SANITARY GRAVITY WORKS ARE TO BE INSTALLED IN ACCORDANCE WITH PROJECT SPECIFICATIONS AND CONSTRUCTION DRAWING DETAILS.
- SANITARY GRAVITY PIPE TO BE PVC DR 28 (LESS THAN 150mm DIAMETER) OR PVC DR35 (GREATER THAN 150mm DIAMETER), U.N.O.
- SANITARY FORCEMAIN PIPE AND FITTINGS ARE TO BE HIGH DENSITY POLYETHYLENE (HDPE) DR17, PE4710 PR, U.N.O.
- WHERE PVC PIPE IS REQUIRED FOR TIE-INS TO EXISTING SANITARY FORCE MAINS, CONTRACTOR IS TO USE PVC C900 CLASS 200 DR14 PIPE WITH MOLDED FITTINGS TO AWWA C907. DUCTILE IRON FITTINGS MAY BE USED BUT ARE TO BE APPROVED BY THE ENGINEER PRIOR TO USE.
- SHOULD SANITARY PIPELINES CROSS ABOVE AN EXISTING WATERMAIN PIPE, THE FOLLOWING GUIDELINES ARE TO BE FOLLOWED:
  - CONTRACTOR WILL BE REQUIRED TO EXCAVATE 3.0m TO EACH SIDE OF THE EXISTING WATERMAIN TO CONFIRM JOINT LOCATIONS.
  - SHOULD A JOINT BE DISCOVERED WITHIN THE 3.0m EXCAVATION (6.0m TOTAL OR 1 PIPE LENGTH) THE CONTRACTOR WILL BE REQUIRED TO WRAP THE PIPE JOINTS IN ACCORDANCE WITH THIS SHEET, SUBHEADING 'WATER'.

**8.0 STRUCTURAL**

- ALL CONCRETE MIX DESIGNS, INSTALLATION METHODS, FINISHING, AND QUALITY CONTROL TESTING IS TO BE IN CONFORMANCE WITH RELEVANT STRUCTURAL SPECIFICATIONS AND CONTRACT DOCUMENTS.
- ALL REINFORCING STEEL AND CONCRETE REINFORCEMENT INSTALLATION METHODS, EMBEDMENT, LENGTHS, COVERS, PLACEMENTS AND QUALITY CONTROL TESTING IS TO BE IN CONFORMANCE WITH RELEVANT STRUCTURAL SPECIFICATIONS AND CONTRACT DOCUMENTS.
- STRUCTURAL STEEL AND STEEL PIPING EXTERIOR/INTERIOR IS TO BE PAINTED IN ACCORDANCE WITH RELEVANT COATING AND PAINTING SPECIFICATIONS AND CONTRACT DOCUMENTS.
- LOCATIONS AND ELEVATIONS OF EXISTING STRUCTURES AS SHOWN ON THE DRAWINGS ARE APPROXIMATE VALUES ONLY AND ARE SUBJECT TO CONSTRUCTION VARIATIONS.

**9.0 ELECTRICAL**

- ALL ELECTRICAL MATERIALS AND INSTALLATION PROCEDURES TO CONFORM WITH APPLICABLE CANADIAN ELECTRICAL CODE, NEPTUNE DESIGN STANDARDS AND APPLICABLE ELECTRICAL CONTRACT SPECIFICATIONS, WHERE APPLICABLE.
- ANY CROSSING BETWEEN WATER, STORM & SANITARY LINES OVER OR PARALLEL TO ELECTRICAL CABLES AND/OR ELECTRICAL DUCTS TO BE CONFIRMED BY THE ENGINEER & NEPTUNE.

**10.0 ENVIRONMENT**

- CONTRACTOR TO CONDUCT ALL CONSTRUCTION ACTIVITIES IN ACCORDANCE WITH THE FOLLOWING DOCUMENTS:
  - VANCOUVER FRASER PORT AUTHORITY PROJECT/BUILDING PERMITS
  - VFPA PER PERMIT NO. 21-172 (DUMPER 2)
  - VFPA PER PERMIT NO. XX-XXX (TO BE CONFIRMED - BERTH 2)
- THE CONTRACTOR SHALL BE RESPONSIBLE FOR ENSURING THE SAFETY AND SECURITY OF ITS AGENTS, EMPLOYEES, AND SUBCONTRACTORS, AND FOR ENSURING THE SECURITY OF NEPTUNE'S OPERATIONS, TO ALL APPLICABLE FIRE, SAFETY, HEALTH AND ENVIRONMENT LAWS, INCLUDING BUT NOT LIMITED TO:
  - WORKSAFEBC AND OCCUPATIONAL HEALTH AND SAFETY REGULATIONS
  - NEPTUNE HEALTH AND SAFETY MANAGEMENT SYSTEM
  - NEPTUNE EMERGENCY PREPAREDNESS AND RESPONSE PLAN
  - ENVIRONMENTAL MANAGEMENT SYSTEM MANUAL.
- CONTRACTOR TO TAKE ALL MEASURES NECESSARY TO MINIMIZE TRACKING OF SOILS ONTO EXISTING ROADS AND ENSURE THAT EXISTING ROADS ARE KEPT CLEAN AND FREE OF EQUIPMENT AND MATERIALS.
- CONTRACTOR WILL AT NO TIME CROSS CONTAMINATE COAL, POTASH AND/OR PHOSROCK PRODUCTS WITH CONSTRUCTION DEBRIS OR EXCAVATED MATERIALS.
- CONTRACTOR WILL AT NO TIME DISPOSE OF ANY CONSTRUCTION DEBRIS OR EXCAVATED MATERIAL SPOIL IN THE SURROUNDING MARINE ENVIRONMENT.

PROJECT: TBD		ENGINEERING SEAL		ENDOR:		ISSUED AS RECORD COPY? (YES/NO) NO		TITLE			
SYSTEM: TBD								BERTH 2 SHIPLOADER PROJECT - CIVIL UNDERGROUND UTILITIES GENERAL NOTES			
ASSET: TBD		A		2023-06-09						ISSUED FOR REVIEW	
DISCIPLINE:		REV		DATE		DESCRIPTION		DRAWN		APPROVED	
DRAWING NO.		DRAWING DESCRIPTION / TITLE		ISSUES / REVISIONS		VENDOR P2P:		SCALE		SHEET OF	
REFERENCE DRAWINGS / DESIGN STANDARDS								AS SHOWN		2 13	
										DRAWING NO.	
										23-0747-GA-002	
										REV	
										A	

P:\2022\22-0747\00 - CAD FILES\DWG\FINAL\22-0747-GA-002.DWG DATE: 2023-05-29

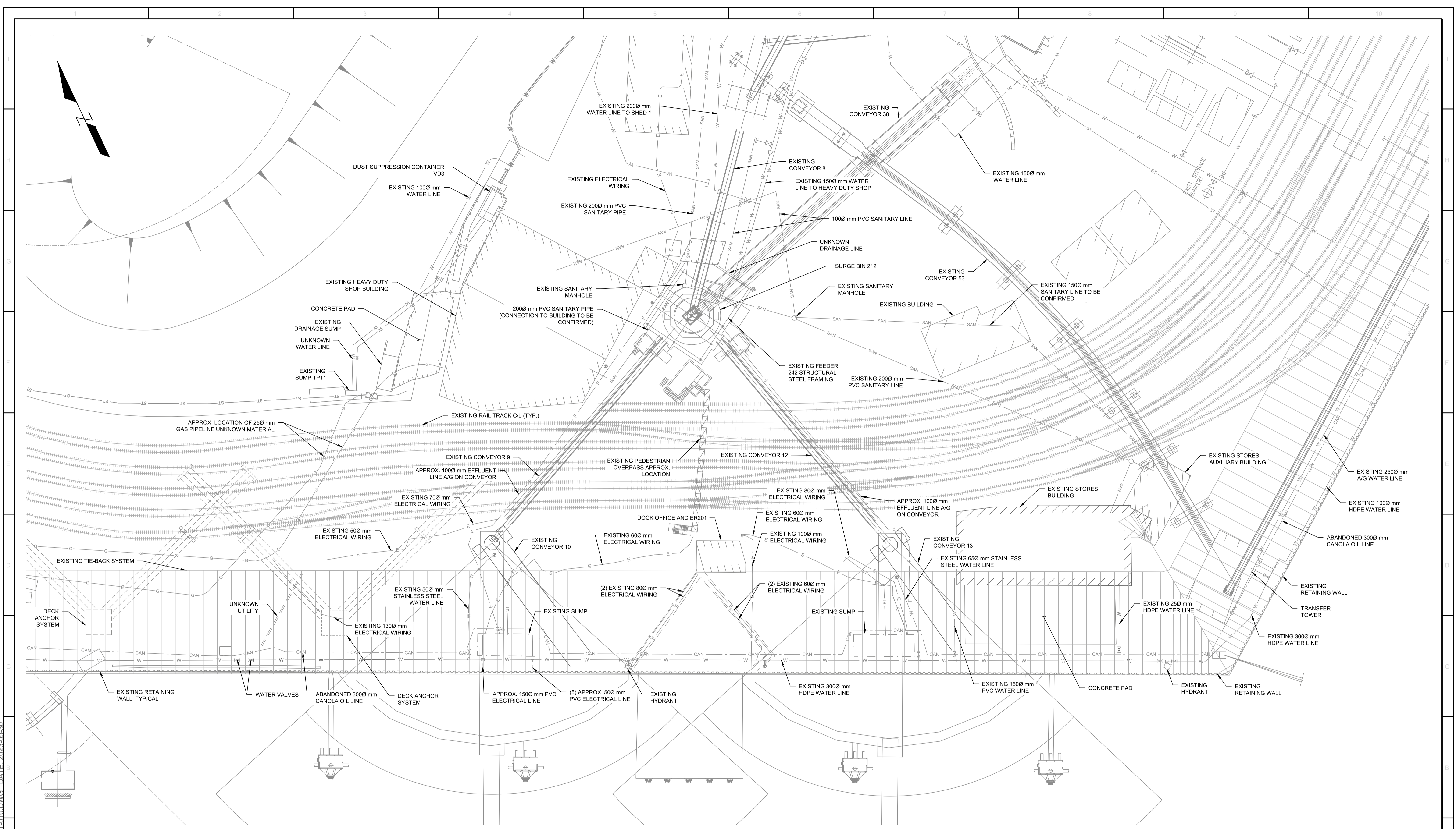

**EXISTING UTILITIES SITE PLAN**  
SCALE: 1:400

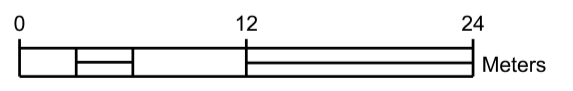

**LEGEND:**

— G —	EXISTING GAS PIPE	— ST —	EXISTING DRAINAGE LINE
— CAN —	EXISTING CANOLA OIL PIPE (ABANDONED)	— S —	EXISTING SUMP
— W —	EXISTING WATER LINE	— F —	EFFLUENT LINE
— E —	EXISTING ELECTRICAL CONDUIT	— V —	EXISTING VALVE
— SAN —	EXISTING SANITARY PIPE	— H —	EXISTING HYDRANT

P:\2022\22-0747-UT-010-CAD FILE\ESID\GVE\N1\22-0747-UT-010.DWG DATE: 2023-05-30

PROJECT: TBD		ENGINEERING SEAL:		VENDOR: <b>BINNIE</b>		ISSUED AS RECORD COPY? (YES/NO) NO		TITLE: BERTH 2 SHIPLOADER PROJECT - CIVIL UNDERGROUND UTILITIES - EXISTING SITE PLAN			
SYSTEM: TBD								SCALE: AS SHOWN SHEET 3 OF 13 DRAWING NO. 22-0747-UT-010 REV: A			
ASSET: TBD											
DISCIPLINE:		REV: 2023-06-09 ISSUED FOR REVIEW JK CV		OEM:							
REFERENCE DRAWINGS / DESIGN STANDARDS		ISSUES / REVISIONS		VENDOR P2P:							



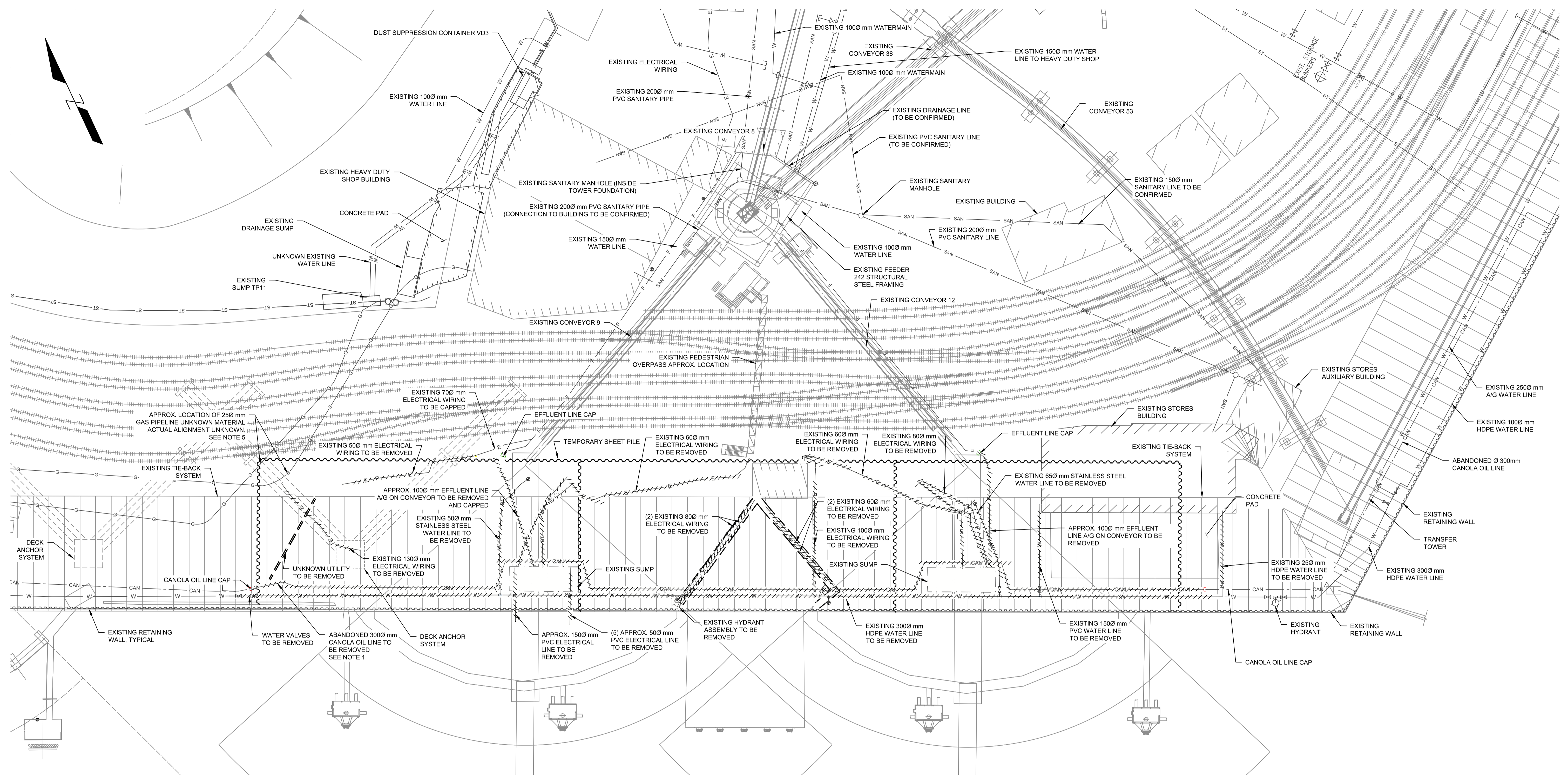

PLAN  
SCALE: 1:400

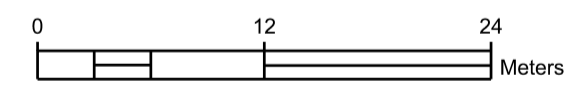

**LEGEND:**

— G —	EXISTING GAS PIPE
— CAN —	EXISTING CANOLA OIL PIPE (ABANDONED)
— W —	EXISTING WATER LINE
— E —	EXISTING ELECTRICAL CONDUIT
— SAN —	EXISTING SANITARY PIPE
— ST —	EXISTING DRAINAGE LINE
— S —	EXISTING SUMP
— F —	EFFLUENT LINE
— V —	EXISTING VALVE
— H —	EXISTING HYDRANT
— / / / / /	UTILITY TO BE DEMOLISHED

- NOTES**
- CANOLA OIL PIPE REMOVAL: CONTRACTOR IS TO BE AWARE THE CANOLA LINE MAY HAVE RESIDUAL PRODUCT WITHIN THE PIPE WITH ASSOCIATED WASTE TYPE WATER INSIDE AS A RESULT. CONTRACTOR SHALL CUT THE TOP OF THE PIPE TO DETERMINE IF FULL WITH WASTEWATER. IF SO, THE WASTEWATER IS TO BE DRAINED AND DISPOSED OF ACCORDINGLY PRIOR TO THE REMOVAL OF THE PIPE. AT REMOVAL BATTERY LIMITS. PIPE IS TO BE CAPPED TO LIMIT INFILTRATION INTO THE REMAINING ABANDONED PIPE.
  - ELECTRICAL CABLES TO BE CONFIRMED DE-ENERGIZED PRIOR TO REMOVAL.
  - REFER TO REFERENCE INFORMATION FOR EXISTING UTILITIES MATERIAL TYPES AND GENERAL DEPTHS.
  - COORDINATE THIS DEMOLITION DRAWING WITH ALL OTHER DEMOLITION DRAWINGS PROVIDED BY OTHER ENGINEERING DISCIPLINES.
  - REFER TO DRAWING 22-0747-UT-301 FOR INSTRUCTIONS REGARDING THE EXISTING GAS LINE WORK PROCEDURES PRIOR TO TEMPORARY SHEET PILE INSTALLATION.

PROJECT: TBD		ENGINEERING SEAL:		VENDOR: <b>BINNIE</b>		ISSUED AS RECORD COPY? (YES/NO) NO		TITLE: BERTH 2 SHIPLOADER PROJECT - CIVIL UNDERGROUND UTILITIES - EXISTING REMOVALS							
SYSTEM: TBD								SCALE: AS SHOWN		SHEET OF 4 13		DRAWING NO. 22-0747-UT-020		REV: A	
ASSET: TBD															
DISCIPLINE:															
DRAWING NO.		DRAWING DESCRIPTION / TITLE		REV		YYYY-MM-DD		DESCRIPTION		DRAWN		APPROVED			
REFERENCE DRAWINGS / DESIGN STANDARDS		ISSUES / REVISIONS		VENDOR P2P:											

P:\2022\22-0747\00 - CAD FILE\ESID\DWG\ENAL\22-0747-UT-020.DWG - DATE: 2023-05-30





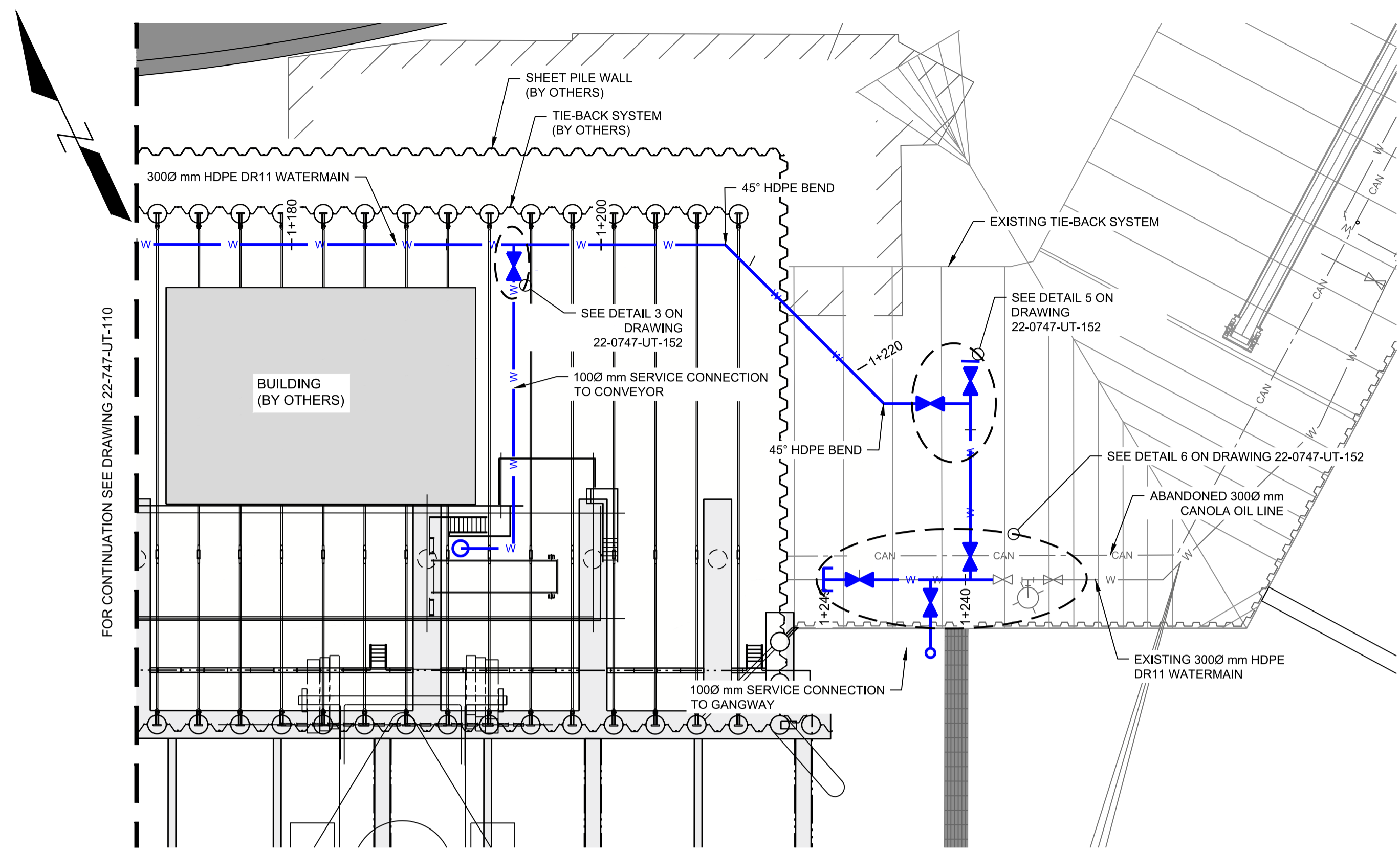

PLAN  
SCALE 1:250

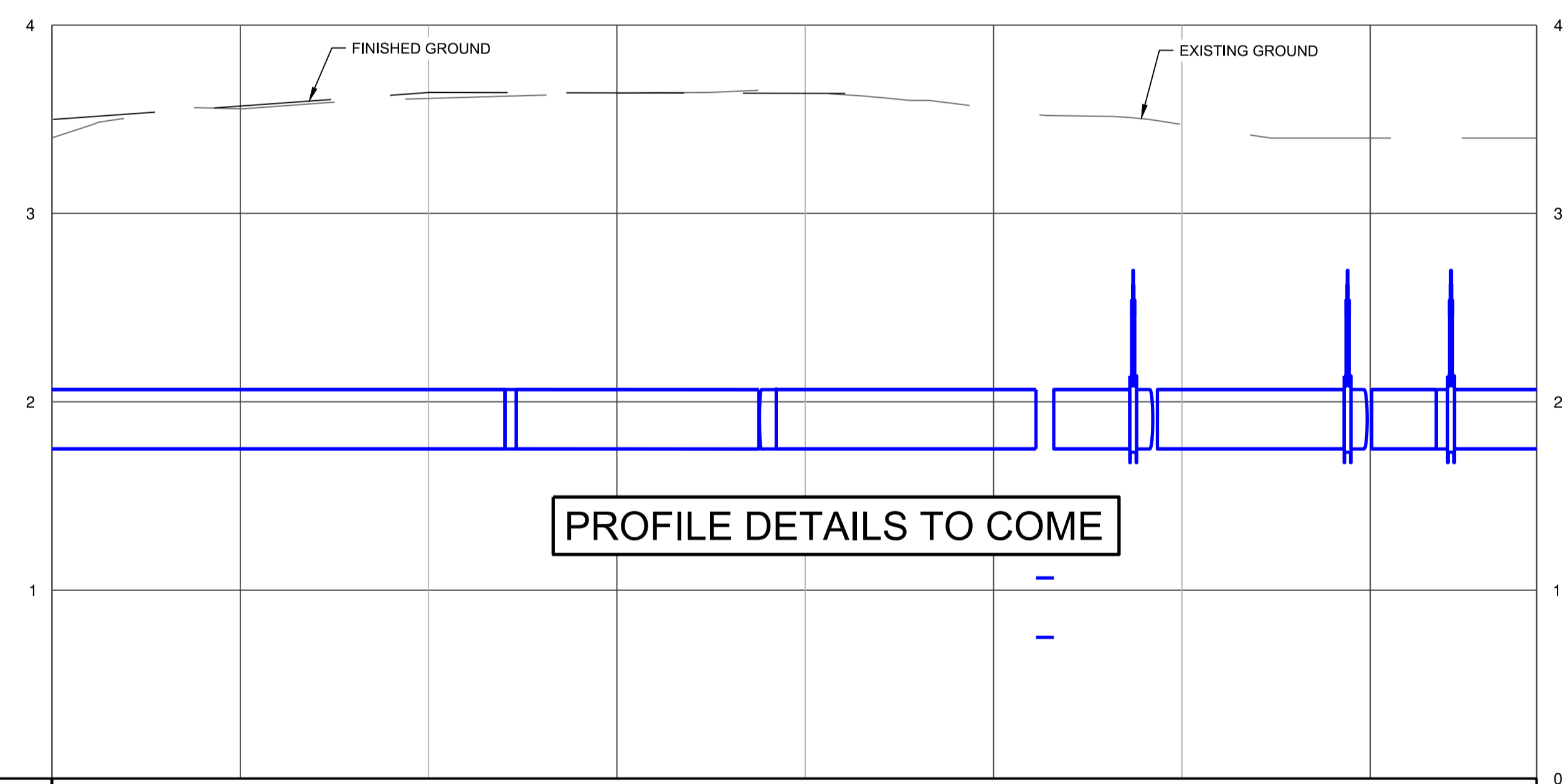
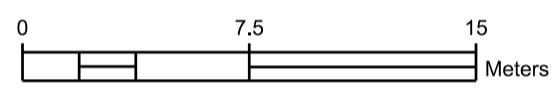

PROFILE  
SCALE H 1:250  
SCALE V 1:50

INVERT ELEVATION (m)	1.75			
PIPE INFO	3000 HDPE DR 11 WATERMAIN			
STATION (m)	1+180	1+200	1+220	1+240

NOTES:

- ALL EXISTING INFORMATION ON STRUCTURES, BURIED/UNDERGROUND SERVICES AND UTILITIES IS BASED ON AVAILABLE RECORDS, RECENT TOPOGRAPHIC SURVEY COMPILED AND THE DAYLIGHTING INFORMATION. ALTHOUGH MEASURES HAVE BEEN TAKEN FOR COMPLETENESS AND ACCURACY, THE CONTRACTOR IS TO CONDUCT THE NECESSARY MEASURES TO LOCATE AND CONFIRM ALL UNDERGROUND UTILITIES WITHIN THEIR WORK AREA AND NOTIFY ENGINEER OF ANY DISCREPANCIES PRIOR TO CONSTRUCTION.
- ALL DIMENSIONS ARE IN METERS UNLESS OTHERWISE NOTED.

PROJECT: TBD		ENGINEERING SEAL:		VENDOR: <b>BINNIE</b>		ISSUED AS RECORD COPY? (YES/NO) NO		TITLE: BERTH 2 SHIPLOADER PROJECT - CIVIL UNDERGROUND UTILITIES - WATERMAIN PLAN & PROFILE - SHEET 2						
SYSTEM: TBD		A 2023-06-09 ISSUED FOR REVIEW JK CV		OEM:		<b>Neptune TERMINALS</b>		SCALE: AS SHOWN		SHEET OF 8 13		DRAWING NO. 22-0747-UT-111		REV: A
ASSET: TBD		REV YYYY-MM-DD DESCRIPTION DRAWN APPROVED		VENDOR P2P:				THIS DRAWING IS THE PROPERTY OF NEPTUNE BULK TERMINALS (CANADA) LTD. NEITHER THIS DRAWING NOR ANY PORTION THEREOF SHALL BE REPRODUCED WITHOUT WRITTEN PERMISSION FROM NEPTUNE BULK TERMINALS (CANADA) LTD.						
DISCIPLINE: CIVIL		ISSUES / REVISIONS												

P:\2022\22-0747\00 - CAD FILE\SIDING\ENAL\22-0747-UT-110-111-120.DWG DATE: 2023-05-30

MINIMUM THRUST AREAS FOR FITTINGS 1MPa PRESSURE AND FOR SOILS WITH MIN. BEARING OF 100kPa										
TYPE OF FITTING	FITTING SIZE (mm)		RECESS IN TRENCH WALL (mm)	LENGTH (mm)	HEIGHT (mm)	TYPE OF FITTING	OUTSIDE OF FITTING TO BEARING FACE (mm)		LENGTH (mm)	HEIGHT (mm)
	D	W					D	W		
90° BEND	150	300	N/A	900	500	CROSS	150	300	650	450
	200	350		200	350		800	650		
	250	375		250	375		1050	800		
	300	400		300	400		1300	950		
45° BEND	150	300	N/A	500	450	45° WYE	150	300	600	450
	200	350		200	350		700	600		
	250	375		250	375		850	750		
	300	400		300	400		1000	900		
22.5° BEND	150	300	N/A	450	250	REDUCER	150	300	600	450
	200	350		200	350		700	600		
	250	375		250	375		850	750		
	300	400		300	400		1000	900		
TEE	150	300	N/A	600	500	CAPS AND PLUGS	150	300	600	450
	200	350		200	350		700	600		
	250	375		250	375		850	750		
	300	400		300	400		1000	900		

REQUIRED RESTRAINED LENGTHS OF PVC PIPE USING UNIFLANGE JOINT RESTRAINERS (m)							MINIMUM COVER 1.5m		
NOM. PIPE DIA. (mm)	90° BEND	45° BEND	22.5° BEND	11.25° BEND	SIZE ON SIZE TEE	VALVE/DEAD-END	45° VERTICAL... OFFSET	22.5° VERTICAL... OFFSET	
150	7	3	1.5	1	7	15	6/2	3/1	
250	10	5	2.5	1.5	15	25	10/3	5/2	

TIE-RODS & LUGS ON FITTINGS		
NOM. PIPE DIA. (mm)	NO. OF LUGS REQ'D ON FITTING	TIE-ROD DIA. (mm)
100 - 300	4	20
400	6	20
HYDRANTS	2	20

FOR PVC PIPE JOINTS

\* ANY JOINTS THAT FALL WITHIN THESE RECOMMENDED LENGTHS SHOULD BE RESTRAINED, ON EACH SIDE OF BENDS, ON THE BRANCH OUTLET OF TEES, AND BEFORE DEAD-ENDS.

\*\* RECOMMENDED RESTRAINED LENGTHS FOR TEES ARE FOR THE BRANCH RUN OUTLET AND ASSUME A MINIMUM 124" SECTION OF PIPE ATTACHED TO EACH RUN. RESTRAINT DEVICES SHOULD ALSO BE INSTALLED ON BOTH RUN JOINTS OF THE TEE ITSELF.

\*\*\* FIRST NUMBER IS THE RECOMMENDED RESTRAINED LENGTH ON EACH SIDE OF A VERTICAL DOWN BEND, THE SECOND NUMBER IS THE LENGTH FOR EACH SIDE OF A VERTICAL UP BEND.

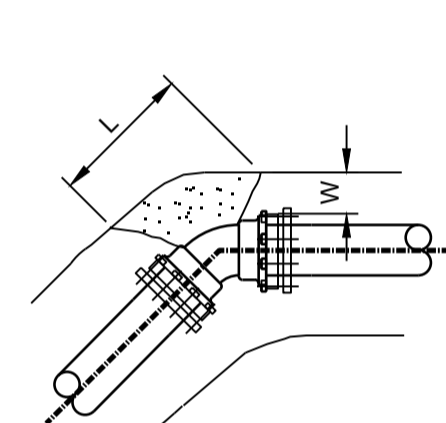

HORIZONTAL 45° BEND

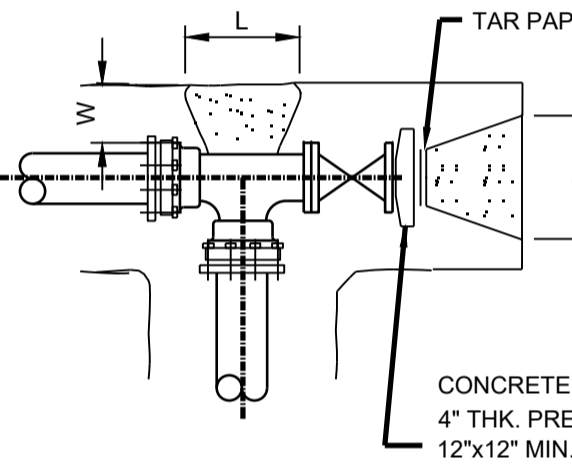

TEE WITH VALVE

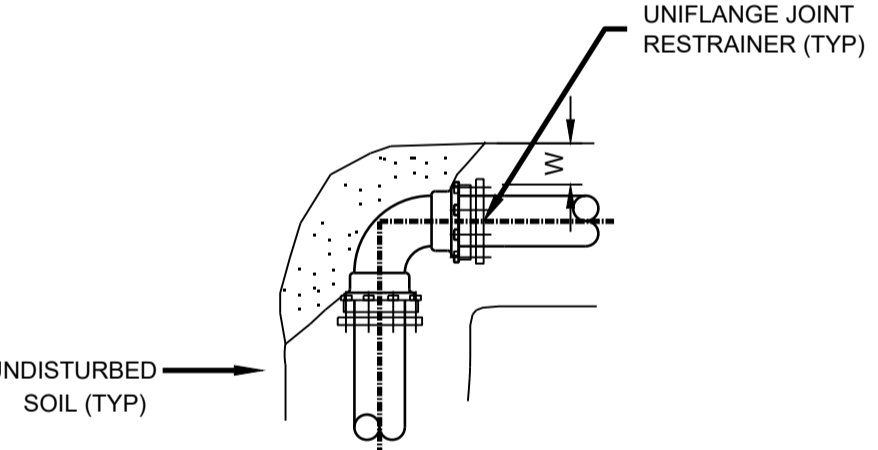

HORIZONTAL 90° BEND

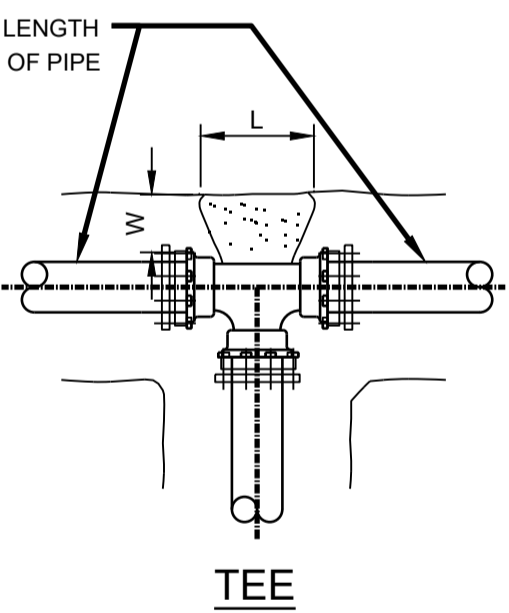

TEE

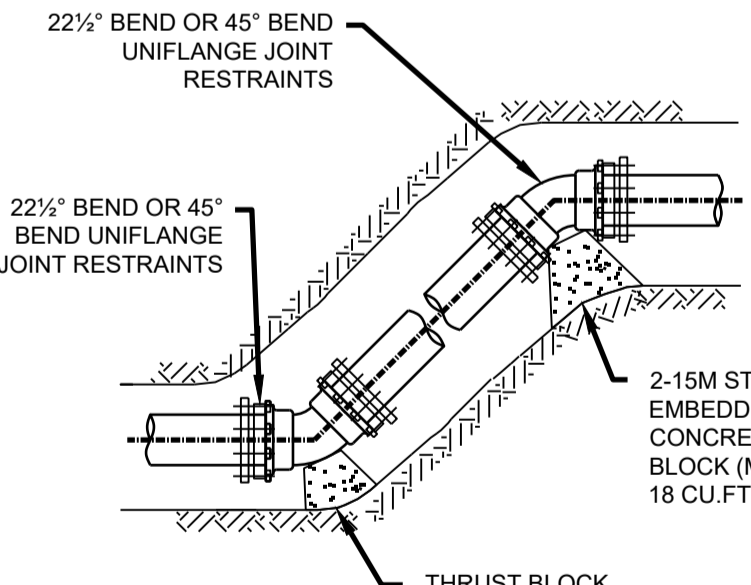

VERTICAL BEND

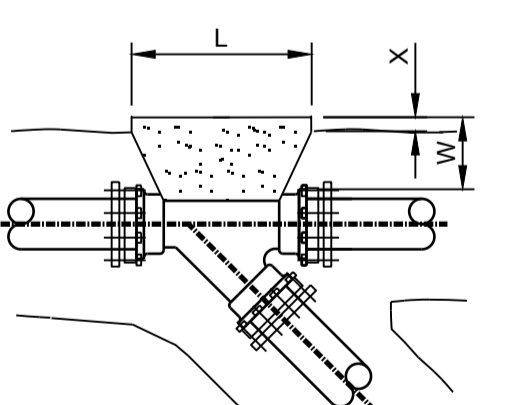

WYE

THRUST BLOCK DETAILS  
N.T.S.

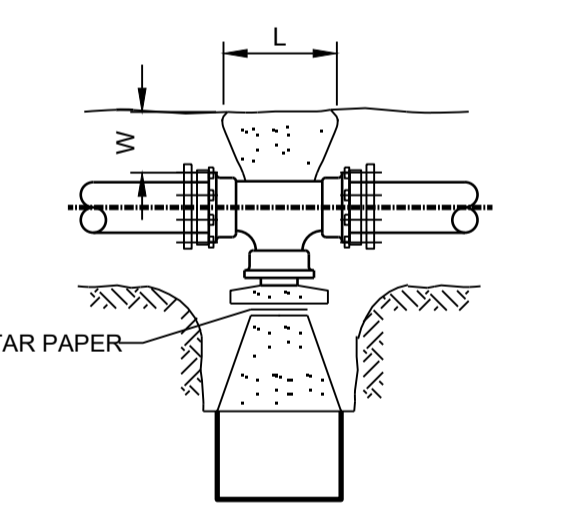

TEE WITH PLUG

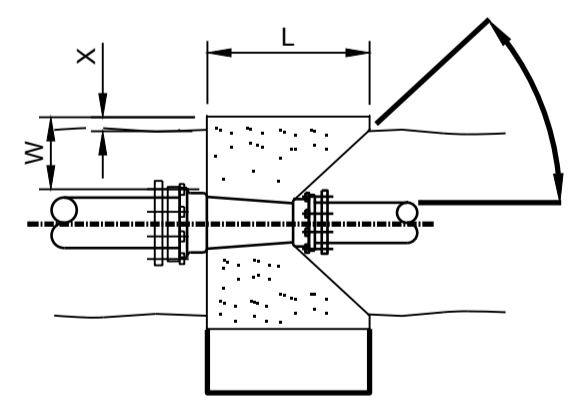

REDUCER

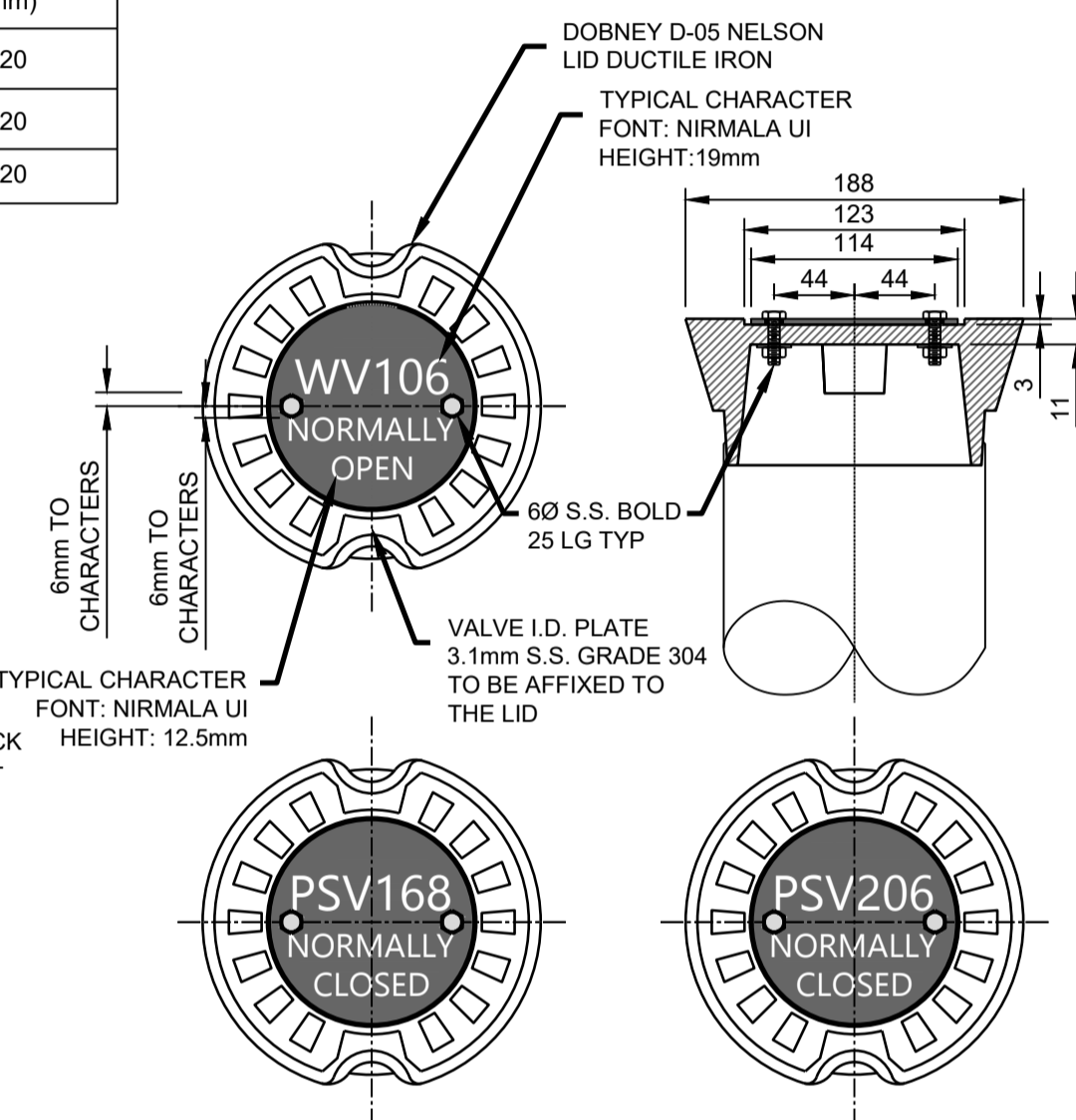

VALVE ID PLATES  
N.T.S.

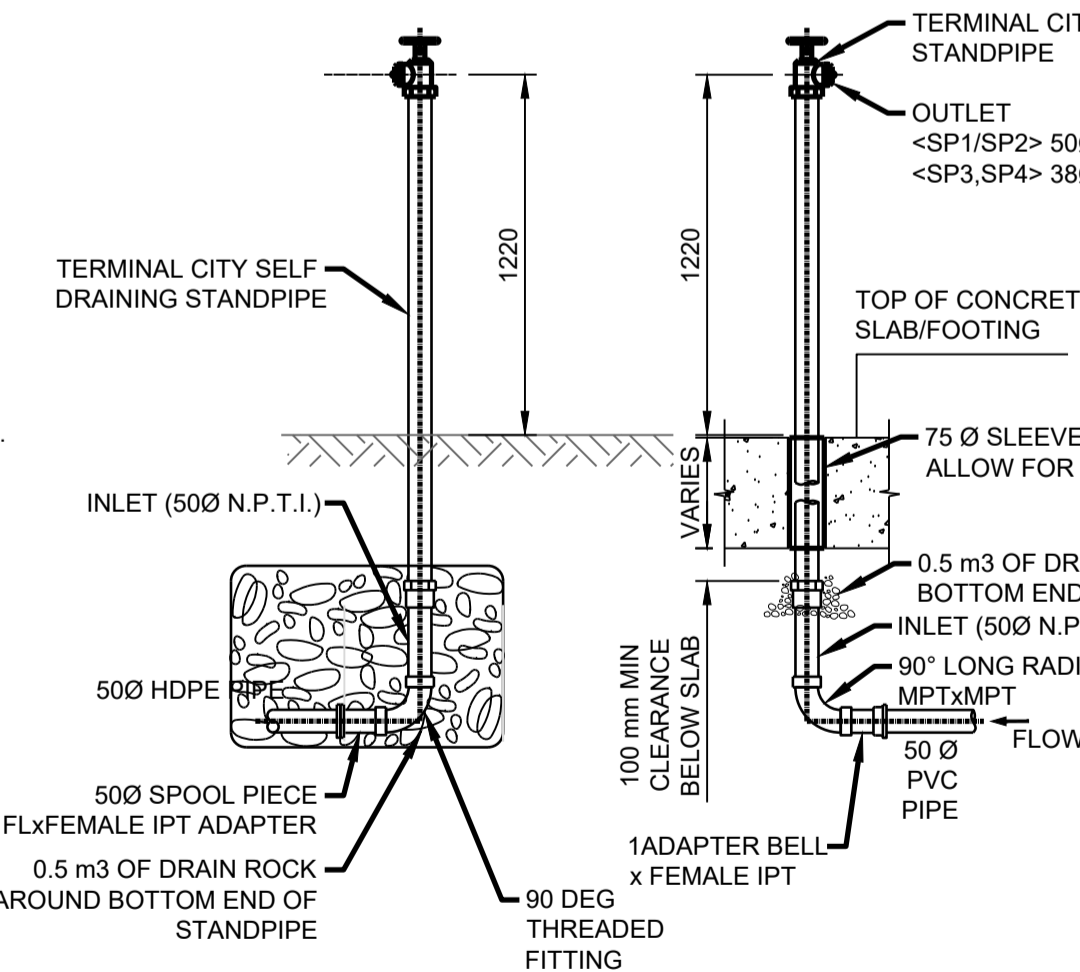

STAND PIPE DETAIL  
N.T.S.

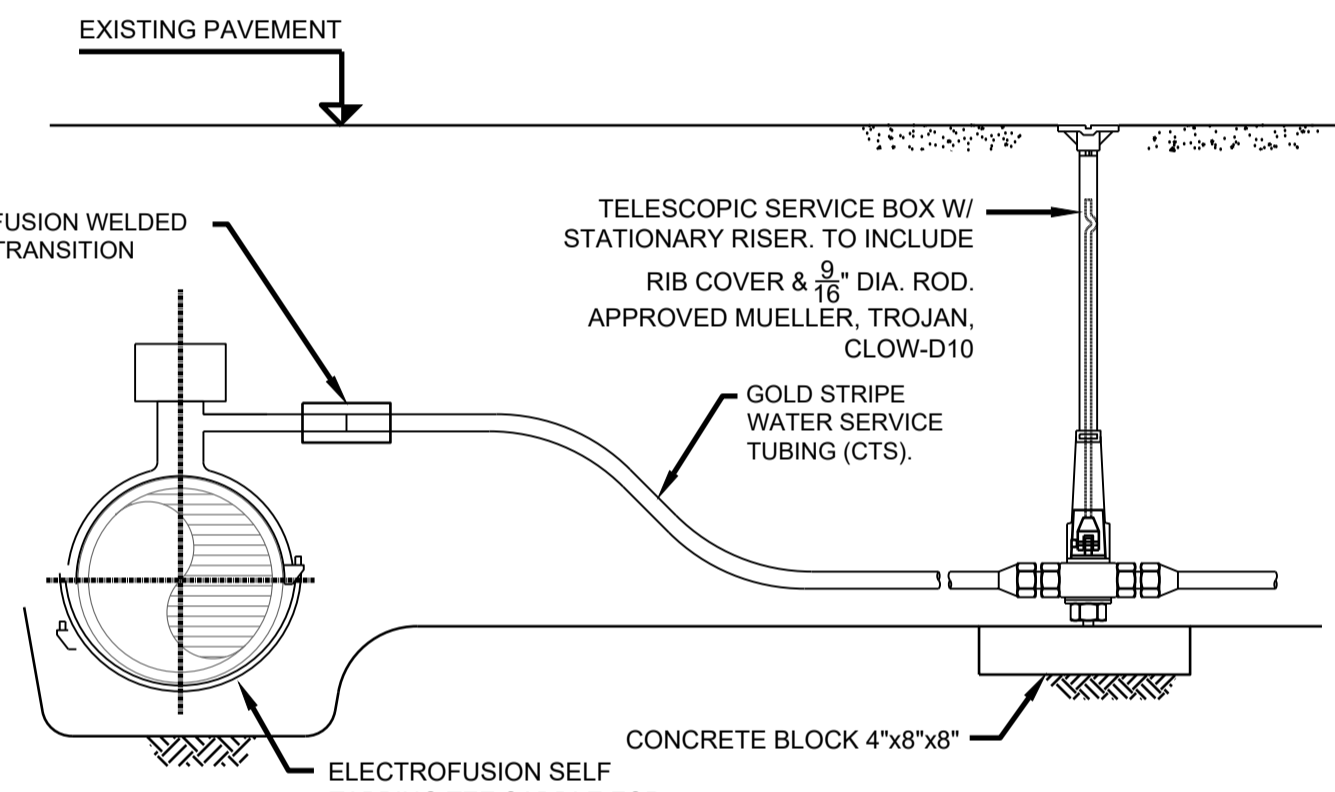

TYPICAL WATER SERVICE CONNECTION DETAIL  
N.T.S.

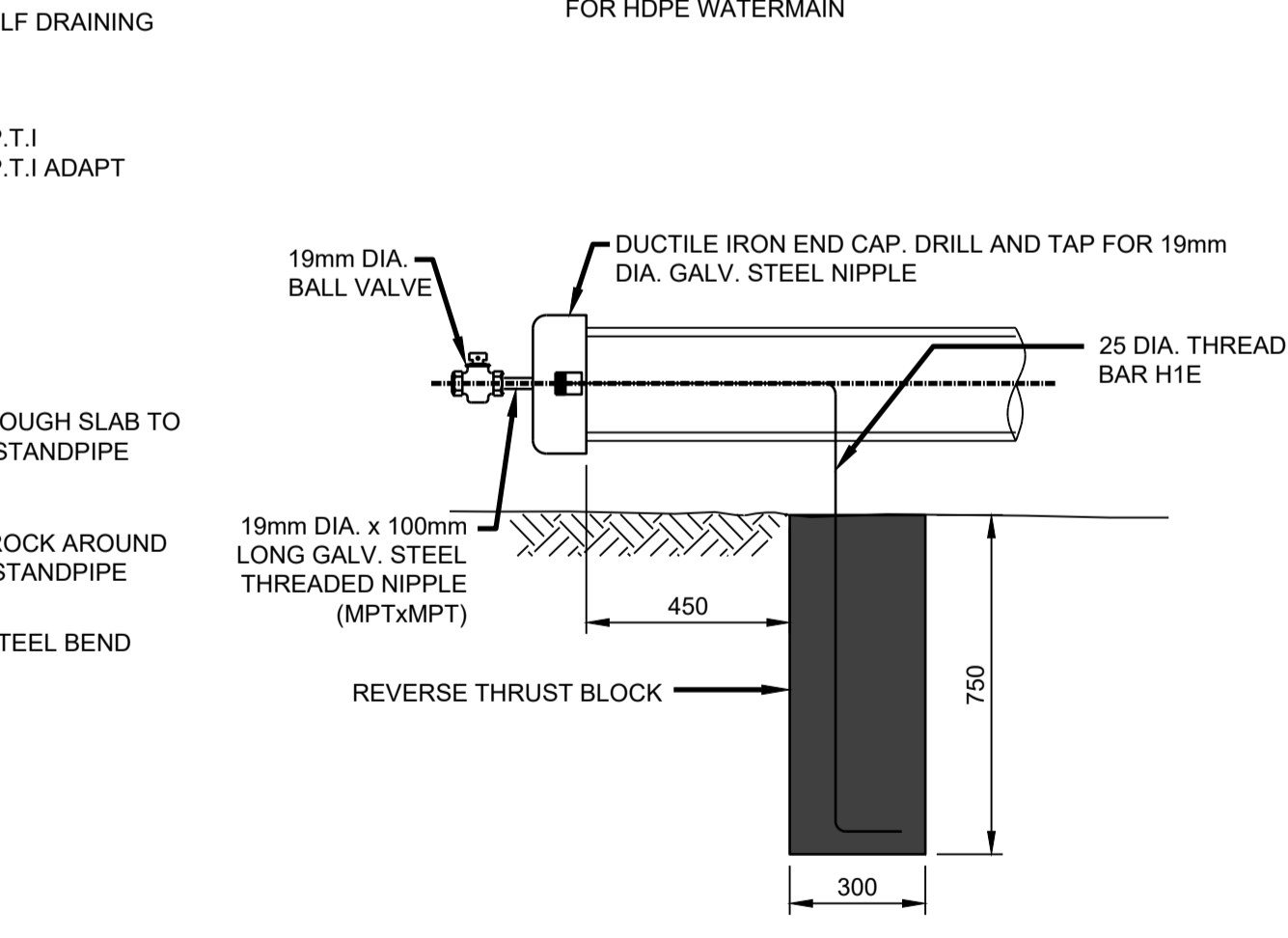

TEMPORARY CAP & TEST LOCATION  
N.T.S.

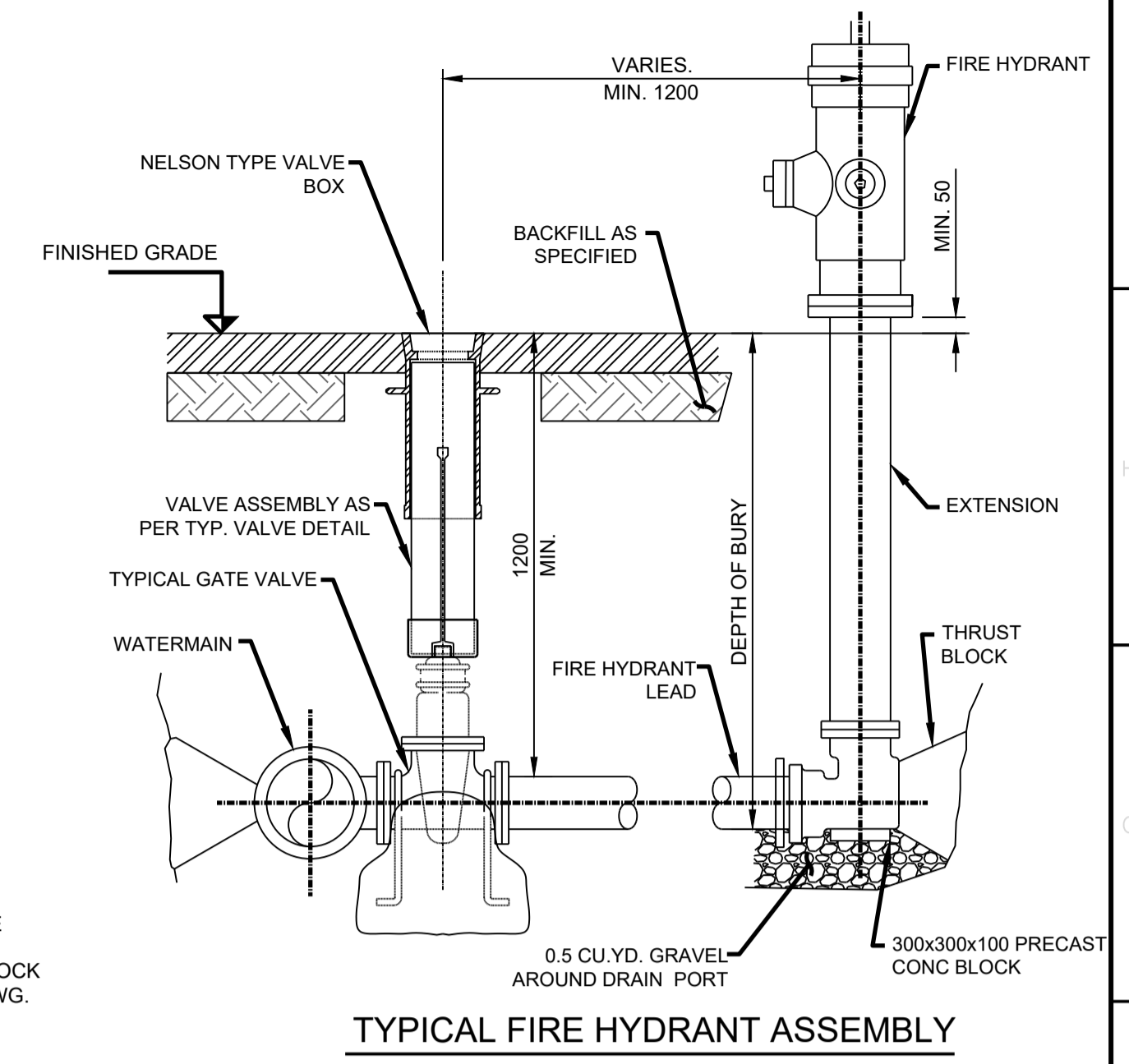

TYPICAL FIRE HYDRANT ASSEMBLY  
N.T.S.

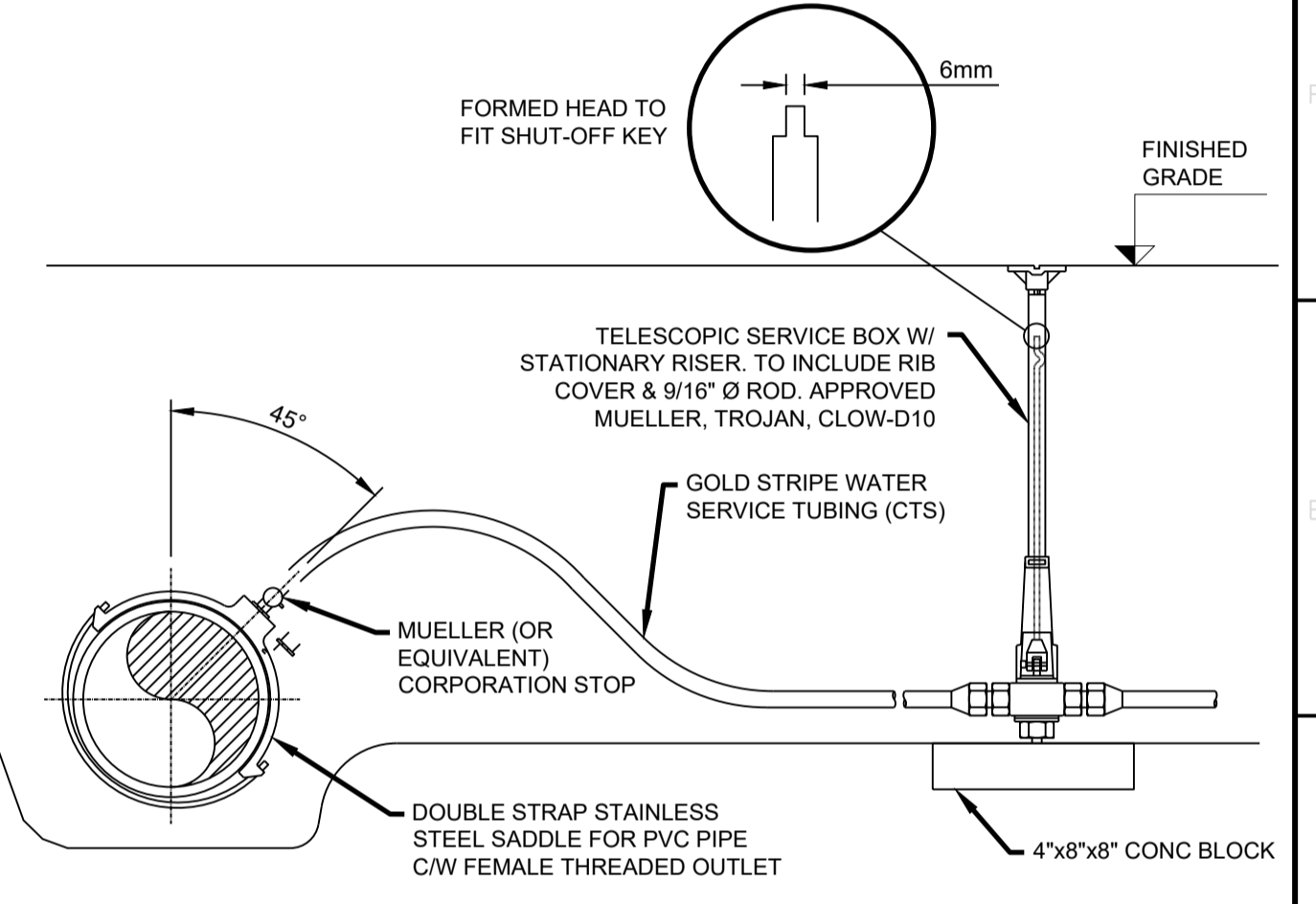

TYPICAL WATER SERVICE CONNECTION DETAIL  
N.T.S.

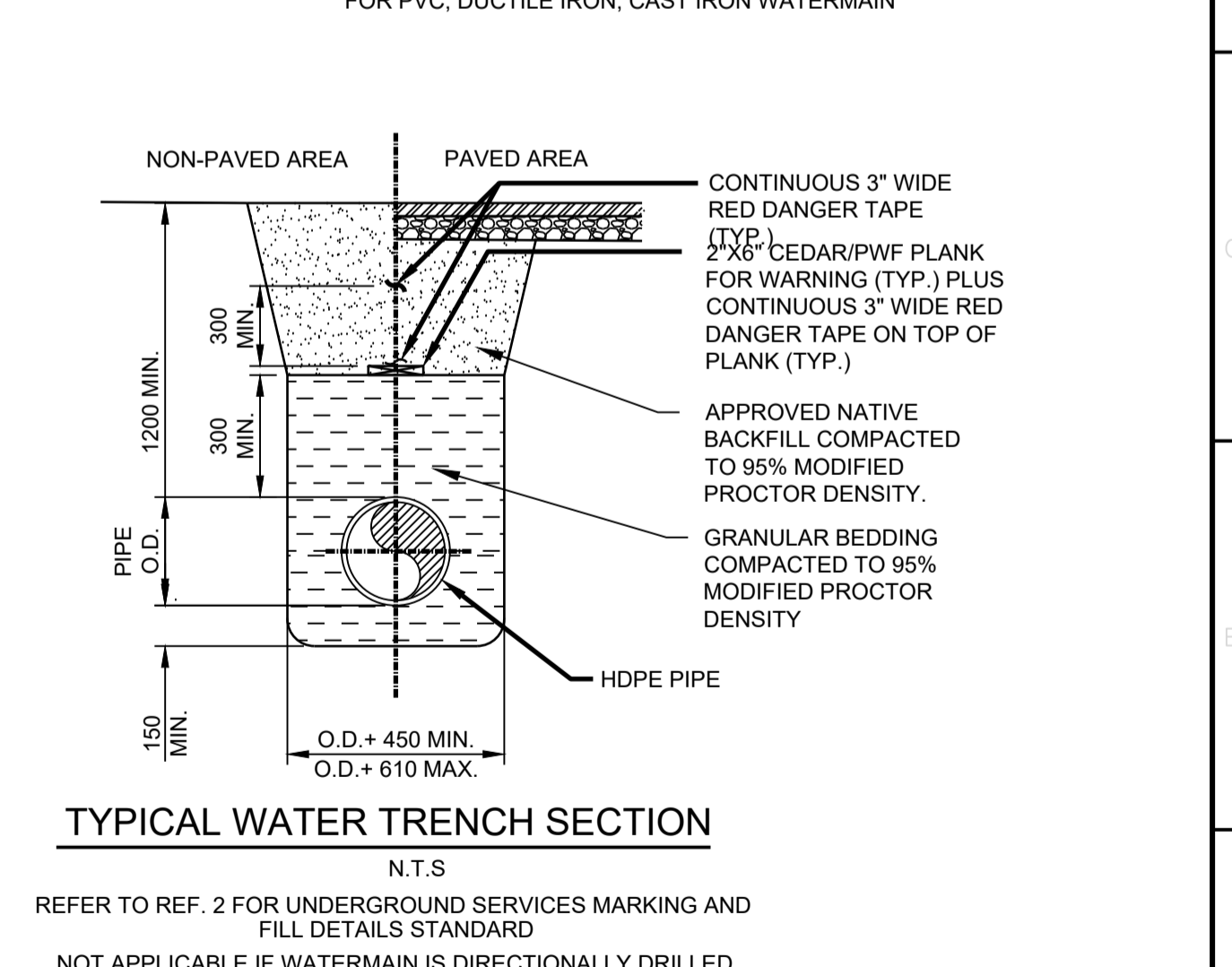

TYPICAL WATER TRENCH SECTION  
N.T.S.

NOTES

- CONTRACTOR IS RESPONSIBLE TO REVIEW PROJECT DESIGN STANDARDS, WHERE APPLICABLE TO THE DETAILS SHOWN ON THIS DRAWING. IF A DISCREPANCY OCCURS BETWEEN RELEVANT DETAILS, NOTIFY ENGINEER.
- GENERAL INSTALLATION REQUIREMENTS NOT NOTED ON GENERAL NOTES DRAWING FOR TYPICAL TRENCH SECTION:  
IF MULTIPLE U/G SERVICES EXIST IN THE SAME VICINITY AND ARE SPACED MORE THAN 300mm CENTER TO CENTER, INDIVIDUAL PLANKS ARE REQUIRED.  
PLANK IS LOCATED 300mm ABOVE TOP OF HIGHEST SERVICE AND CENTERED ABOVE ALL SERVICES WITHIN 300mm CENTERS.  
USE 3" WIDE RED DANGER TAPE ALONG PLANK AND ANOTHER TAPE 300mm ABOVE PLANK AS SHOWN.  
PLANK IS 2"X 6" CEDAR/PWF WOOD.  
FOR EXCAVATION ANGLES AND TO CHECK IF SHORING IS REQUIRED, SEE ENVIRONMENTAL MANAGEMENT PLAN DOCUMENT: 09-900-6-008-00 EXCAVATION & DRILLING DECISION TREE & SAFETY PROCEDURES ON NBT DOCUMENTS.
- ALL TEMPORARY END CAPS TO BE MARKED BY 2x4 EXTENDING 1.2m ABOVE GRADE AND PAINTED BLUE TO SIGNIFY WATERMAIN.  
UNIFLANGE JOINT RESTRAINERS AND THRUST BLOCKS ARE TO BE INSTALLED AT ALL BENDS AND FITTINGS. REFER TO TABLE FOR REQUIREMENTS.
- ALL FIRE HYDRANT LEADS ARE TO BE 150 DIA. PVC CLASS 305 DR14
- PIPE JOINT DEFLECTION TO BE AS PER MANUFACTURERS SPECIFICATIONS AND RECOMMENDATIONS.
- REFER TO GENERAL NOTES ON REF. 1 FOR GENERAL REQUIREMENTS

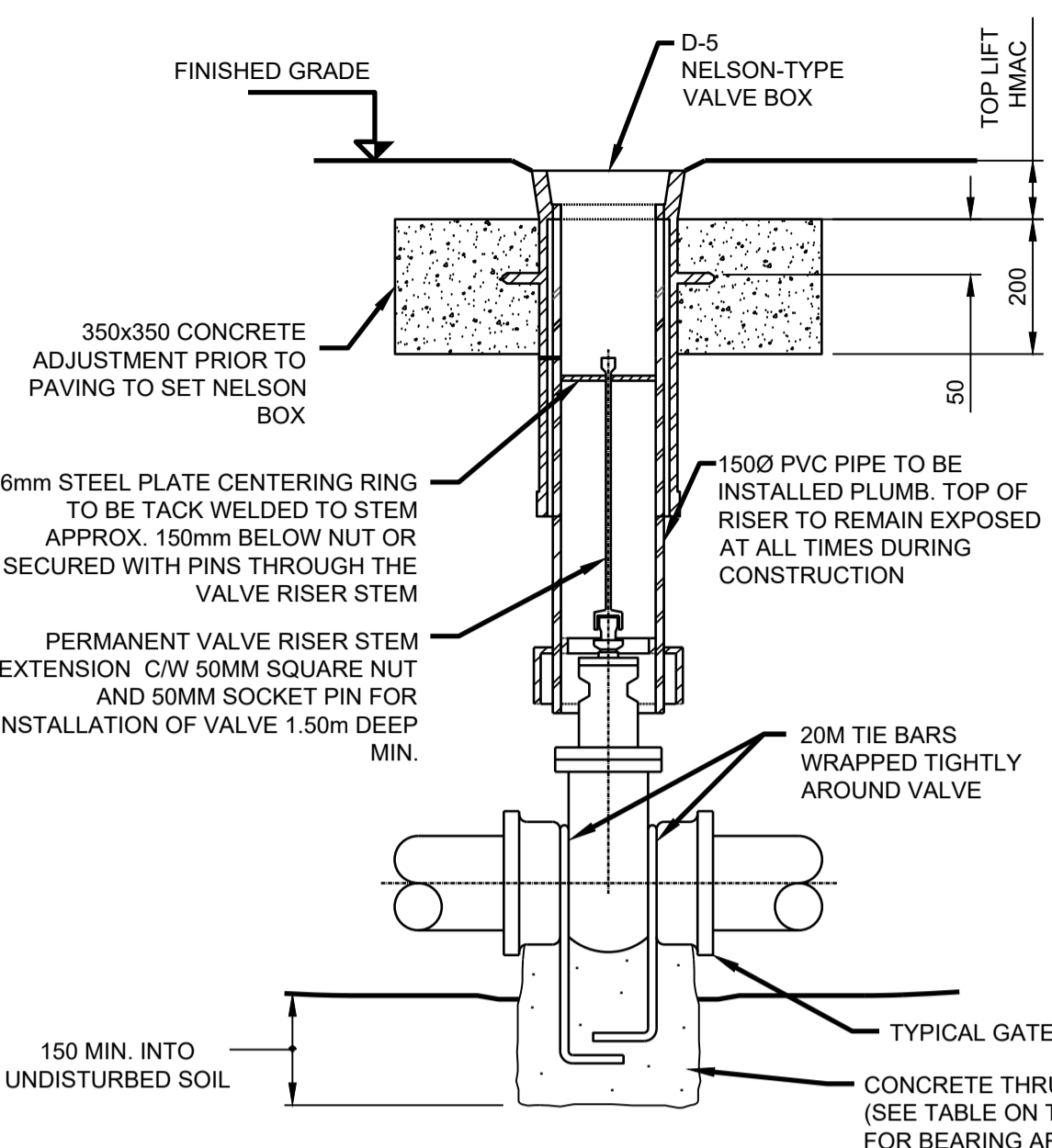

TYPICAL GATE VALVE INSTALLATION  
N.T.S.

REFER TO REF. 3 FOR NBT VALVE BOX DETAIL STANDARD

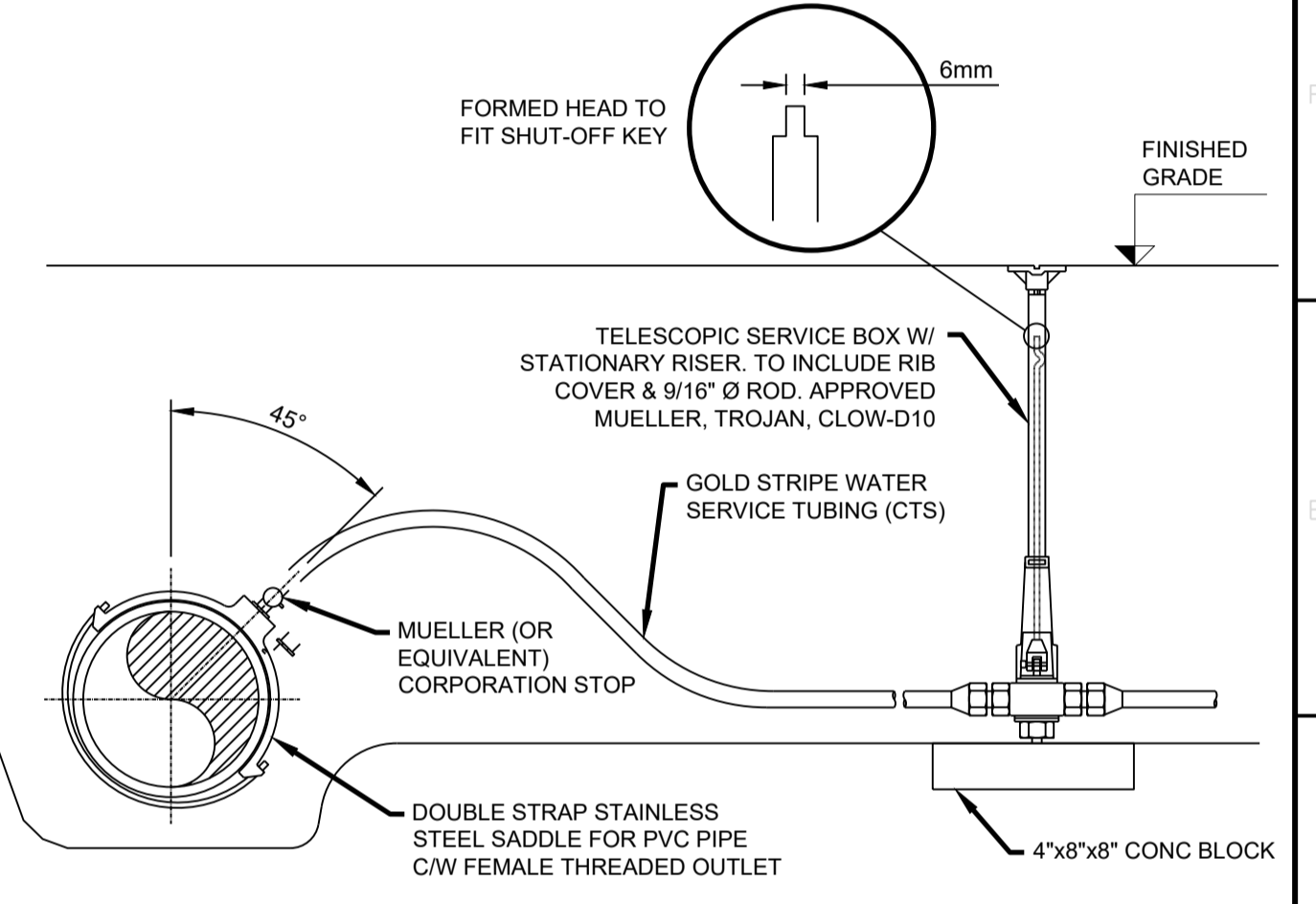

TYPICAL WATER SERVICE CONNECTION DETAIL  
N.T.S.

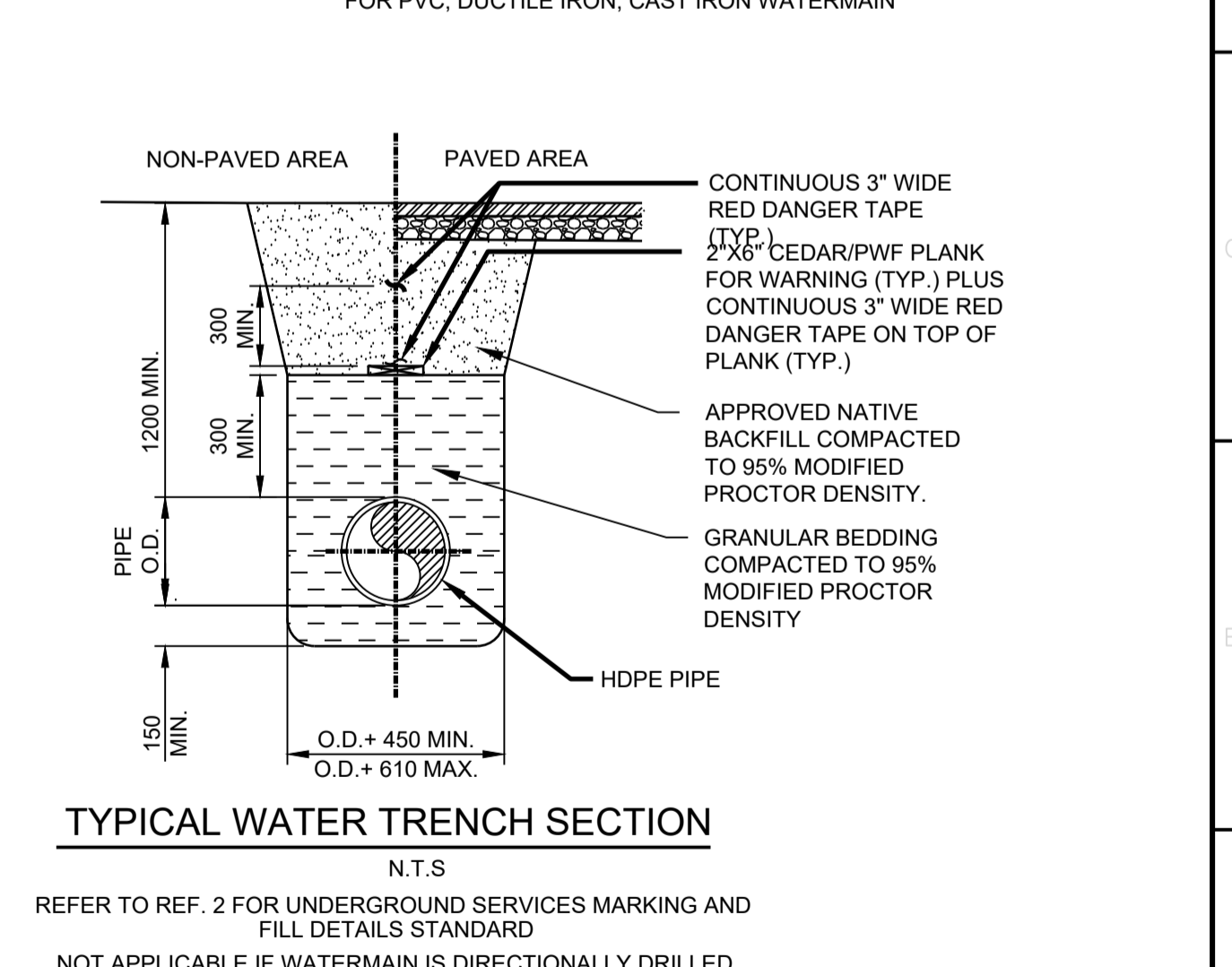

TYPICAL WATER TRENCH SECTION  
N.T.S.

PROJECT:	TBD
SYSTEM:	TBD
ASSET:	TBD
DISCIPLINE:	

ENGINEERING SEAL:				
VENDOR:				
OEM:				
VENDOR P2P:				

ISSUED AS RECORD COPY? (YES/NO) NO

THIS DRAWING IS THE PROPERTY OF NEPTUNE BULK TERMINALS (CANADA) LTD. NEITHER THIS DRAWING NOR ANY PORTION THEREOF SHALL BE REPRODUCED WITHOUT WRITTEN PERMISSION FROM NEPTUNE BULK TERMINALS (CANADA) LTD.

TITLE			
BERTH 2 SHIPLOADER PROJECT - CIVIL UNDERGROUND UTILITIES - WATERMAIN TYPICAL DETAILS - SHEET 1			
SCALE	SHEET OF	DRAWING NO	REV
AS SHOWN	10 13	22-0747-UT-150	A

P:\2022\22-0747\00 - CAD FILES\DWG\FINAL\22-0747-UT-150.DWG DATE: 2023-05-29

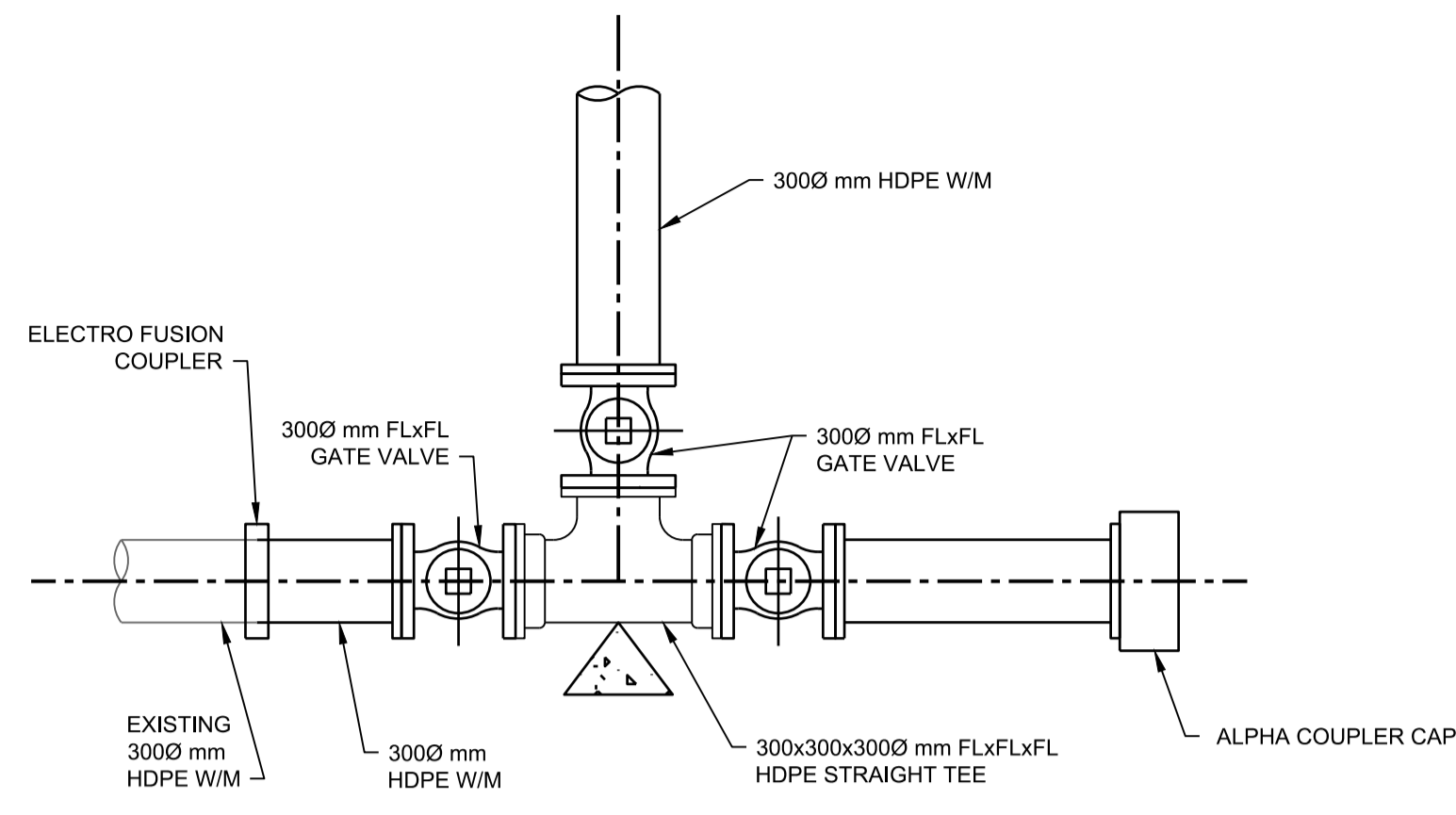

DETAIL 1  
SCALE N.T.S.

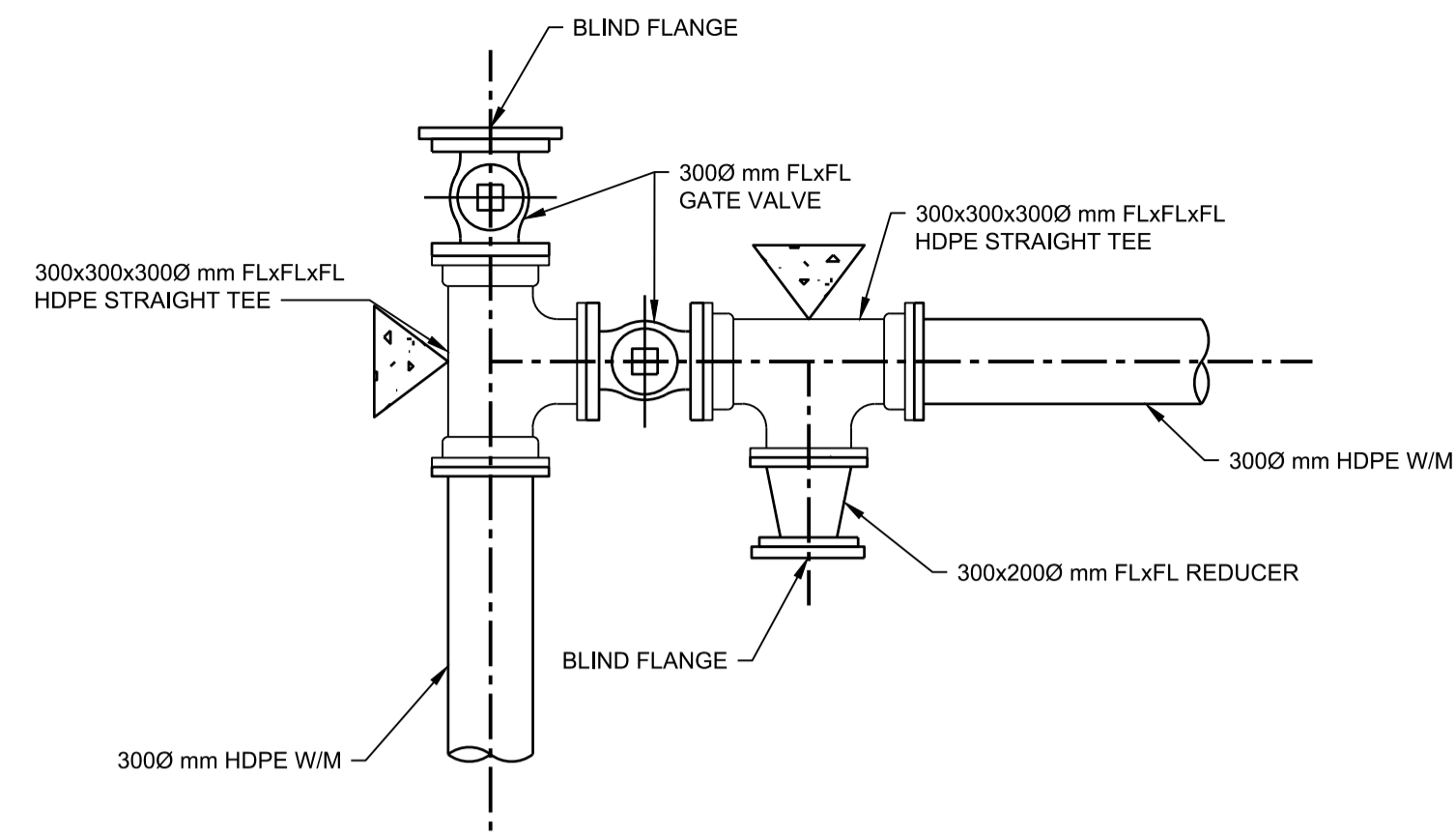

DETAIL 2  
SCALE N.T.S.

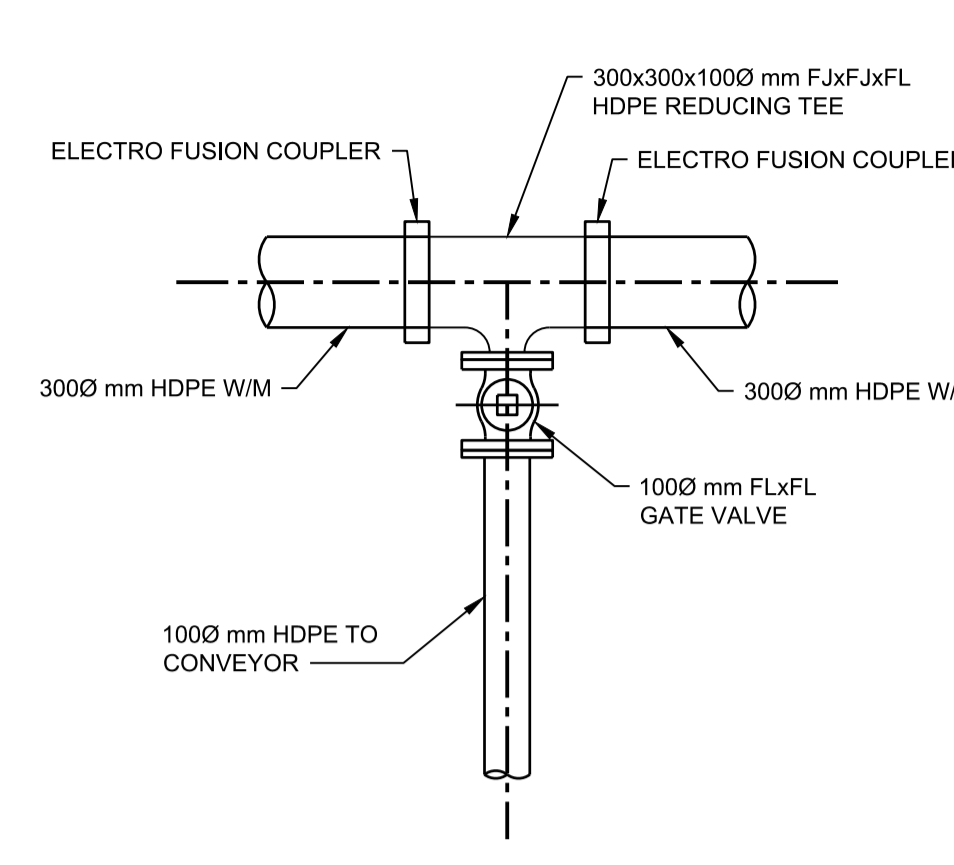

DETAIL 3  
SCALE N.T.S.

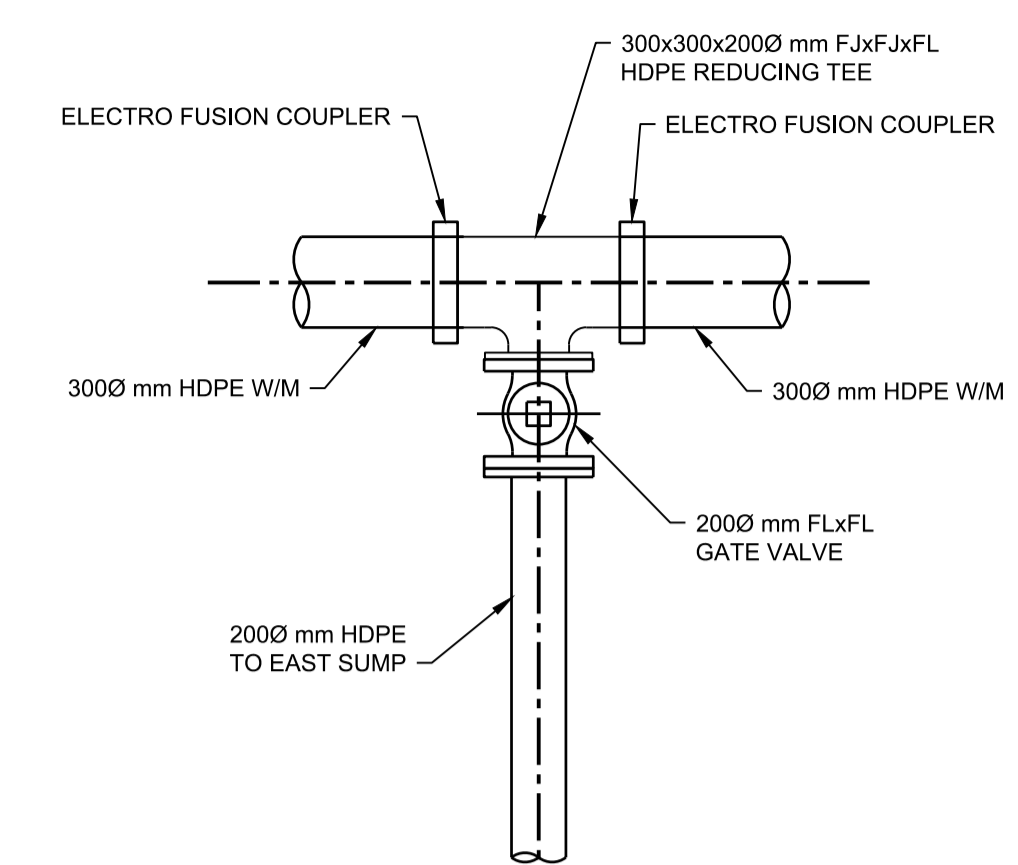

DETAIL 4  
SCALE N.T.S.

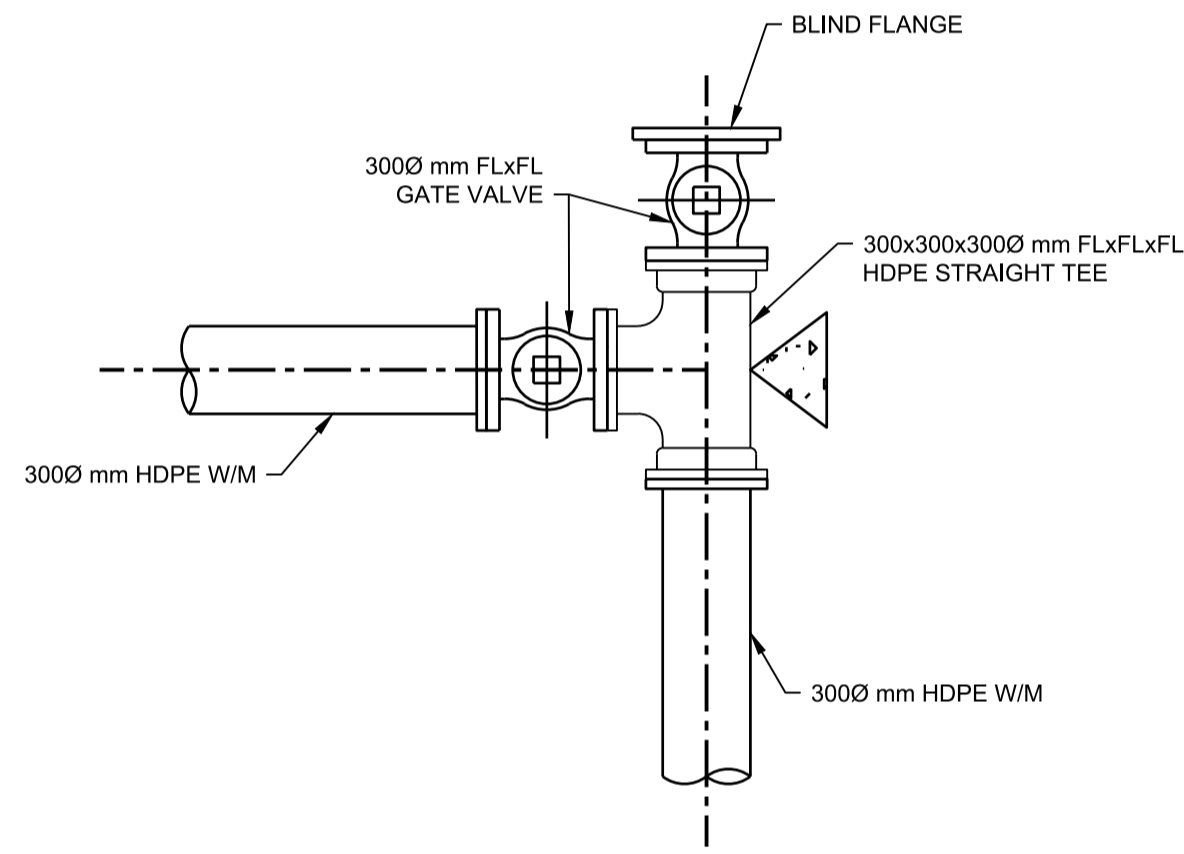

DETAIL 5  
SCALE N.T.S.

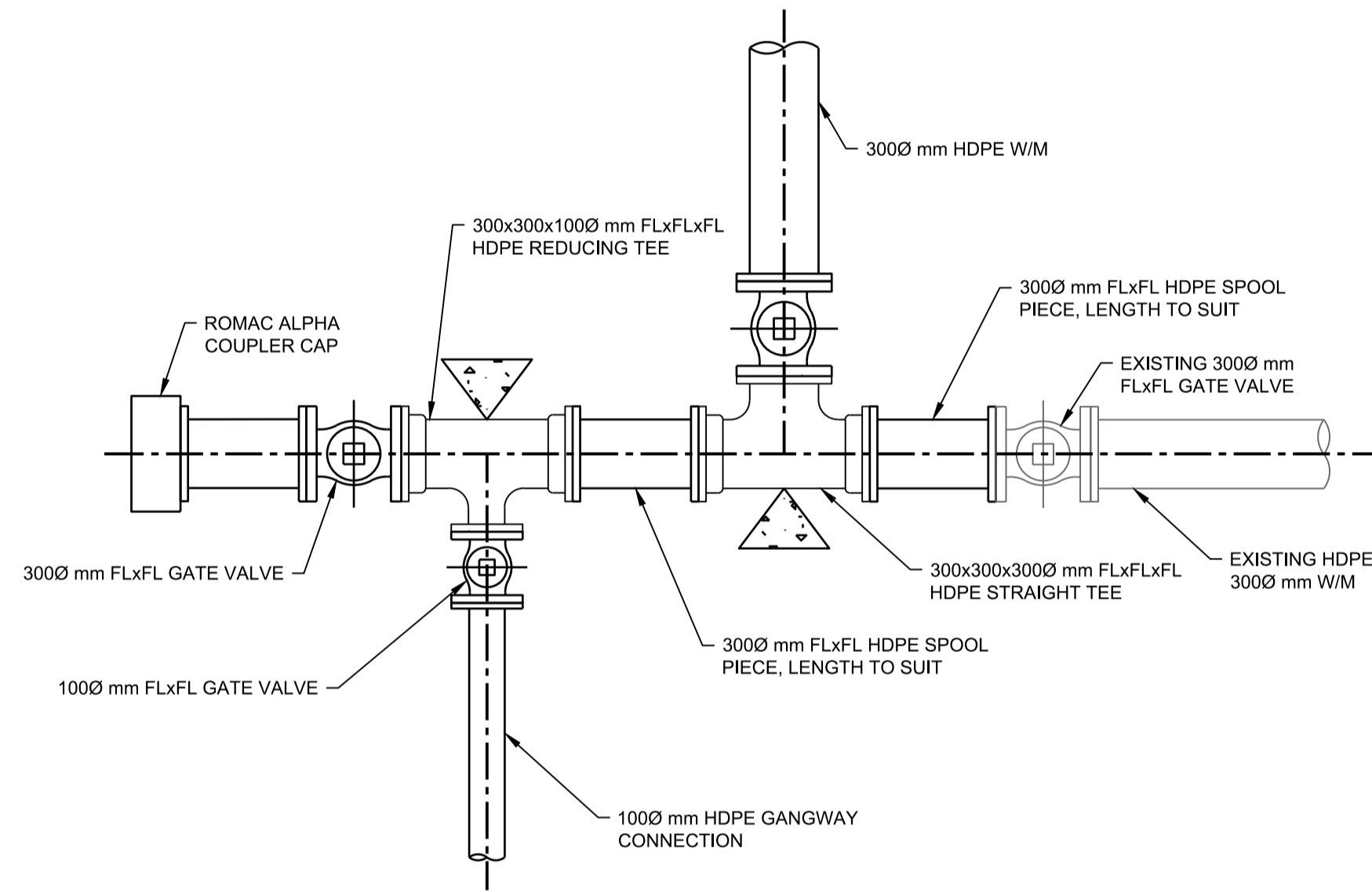

DETAIL 6  
SCALE N.T.S.

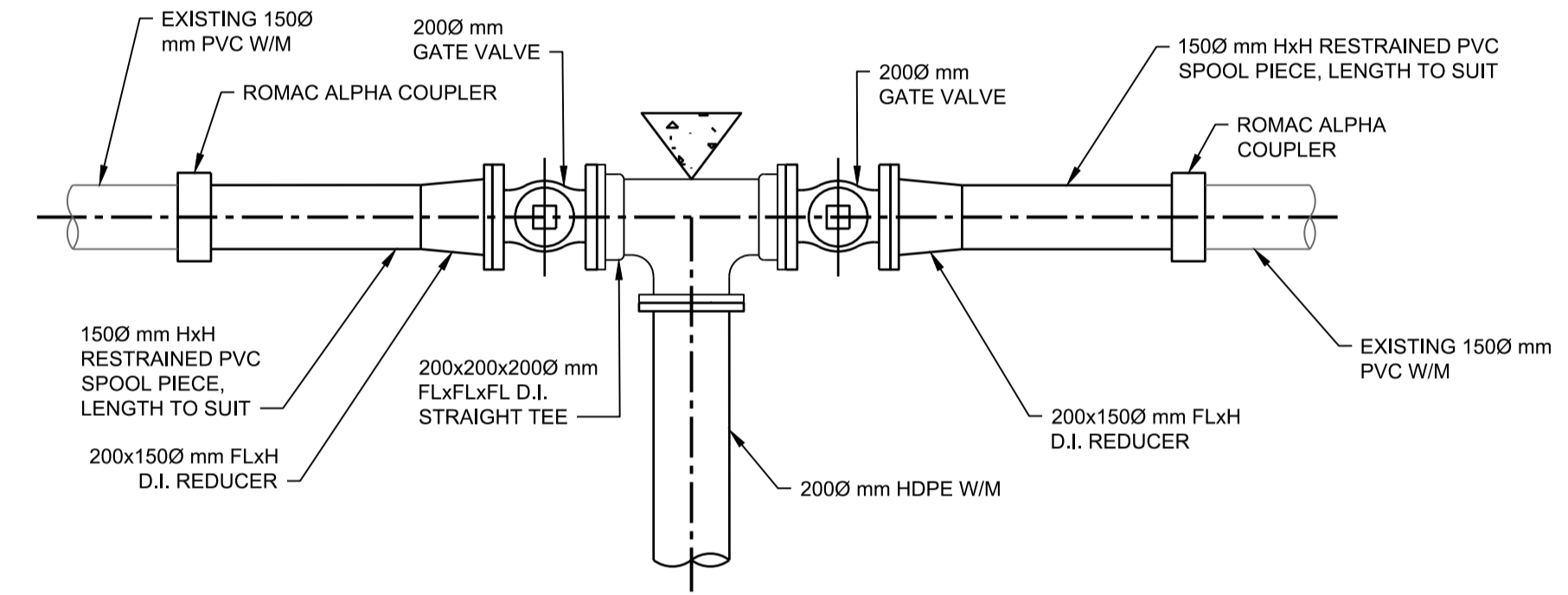

DETAIL 7  
SCALE N.T.S.

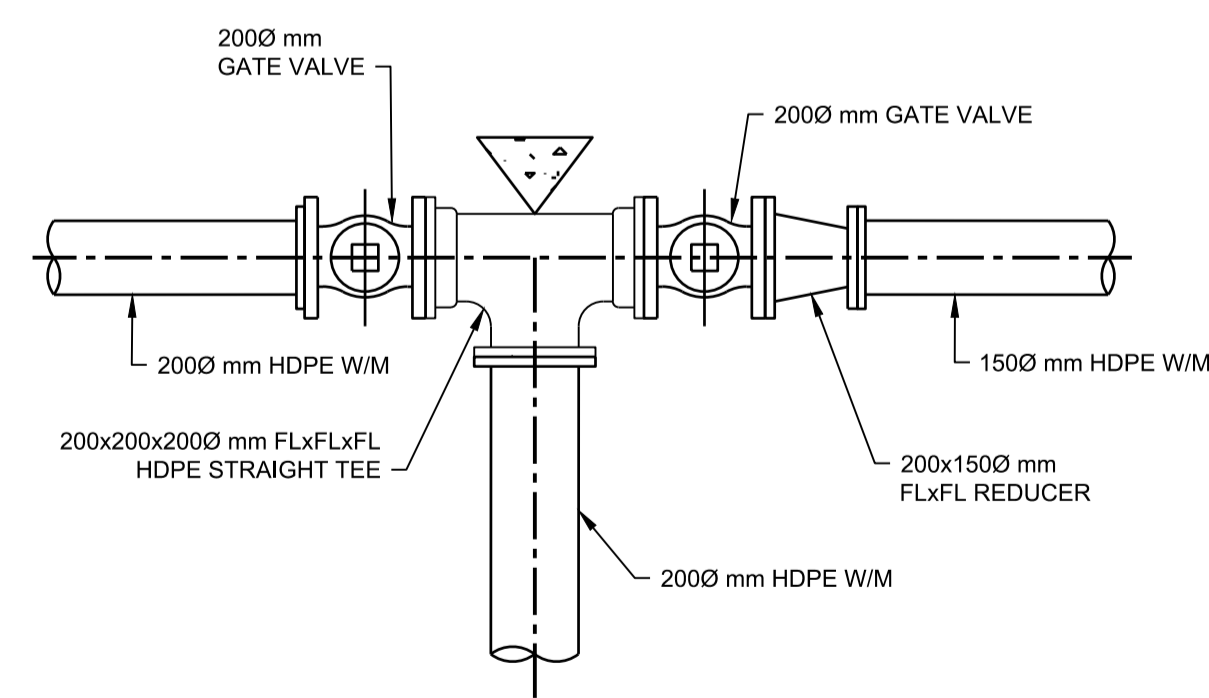

DETAIL 8  
SCALE N.T.S.

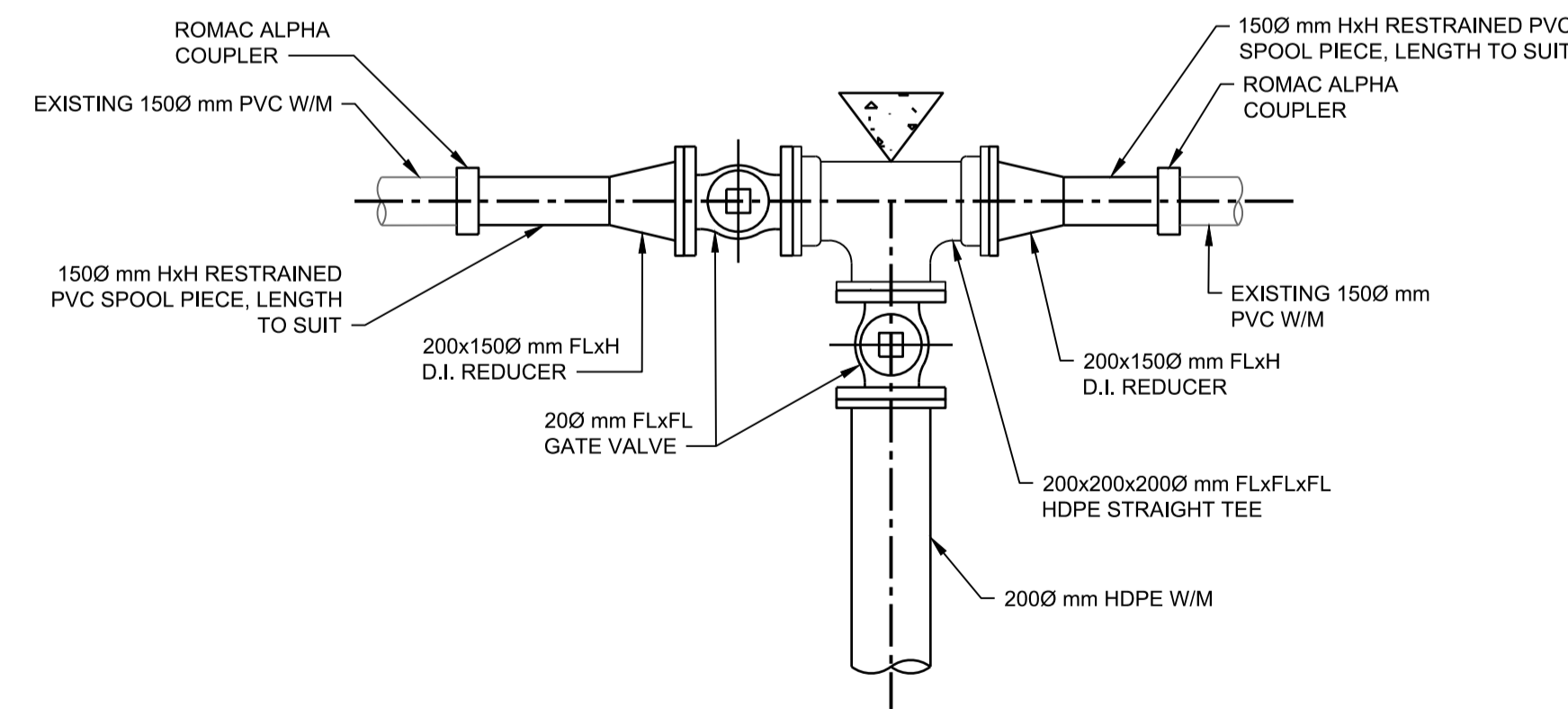

DETAIL 9  
SCALE N.T.S.

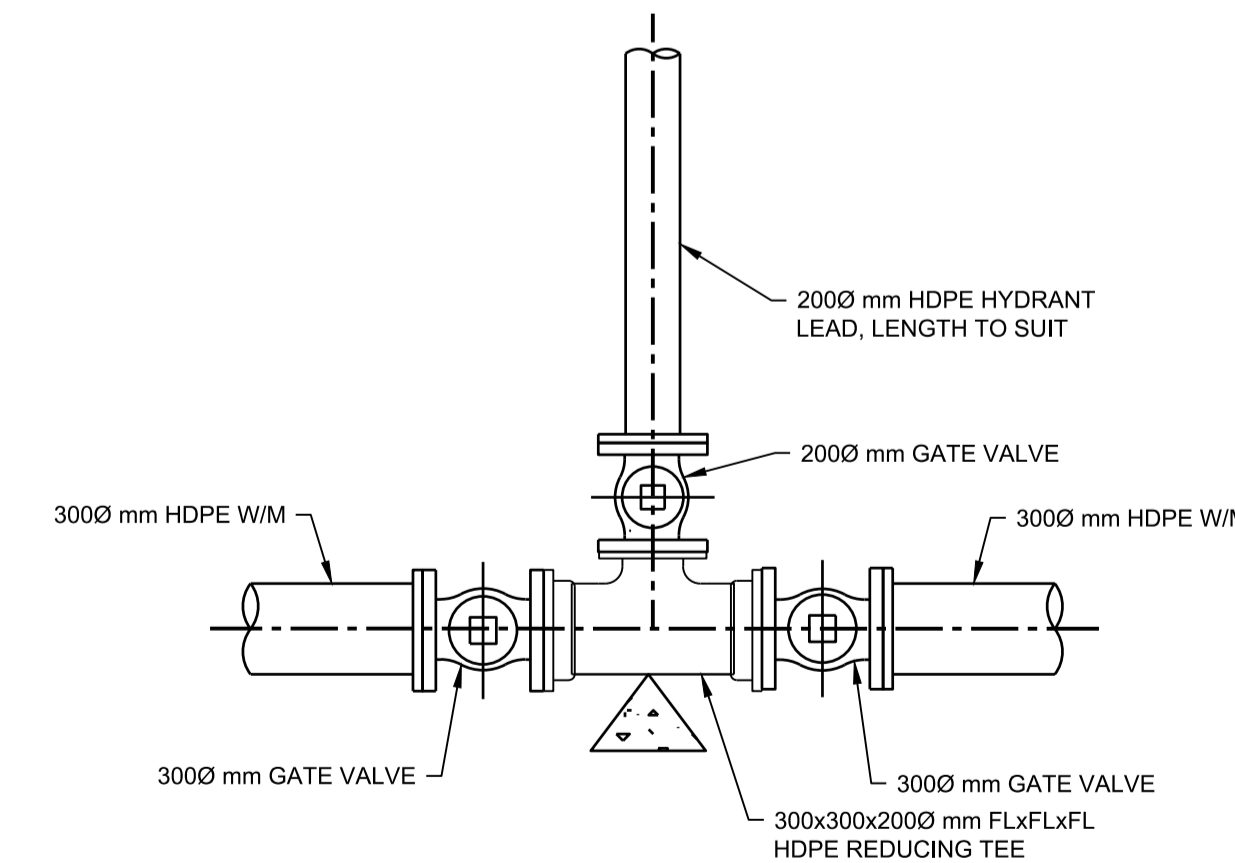

DETAIL 10  
SCALE N.T.S.

NOTES:

- FOR THRUST BLOCKS REQUIREMENTS REFER TO TYPICAL DETAILS ON DRAWING 22-0747-UT-150.
- ALL DUCTILE IRON PIPING AND FITTING BELOW GRADE TO BE DENSO-TAPED.

PROJECT: TBD  
SYSTEM: TBD  
ASSET: TBD  
DISCIPLINE: CIVIL

REV	YYYY-MM-DD	DESCRIPTION	DRAWN	APPROVED
A	2023-06-09	ISSUED FOR REVIEW	JK	CV
ISSUES / REVISIONS				

ENGINEERING SEAL:  
VENDOR P2P:

VENDOR:  
OEM:



ISSUED AS RECORD COPY? (YES/NO) NO  
THIS DRAWING IS THE PROPERTY OF NEPTUNE BULK TERMINALS (CANADA) LTD. NEITHER THIS DRAWING NOR ANY PORTION THEREOF SHALL BE REPRODUCED WITHOUT WRITTEN PERMISSION FROM NEPTUNE BULK TERMINALS (CANADA) LTD.

TITLE:  
BERTH 2 SHIPLOADER PROJECT - CIVIL  
UNDERGROUND UTILITIES - WATERMAIN  
DETAILS - SHEET 1

SCALE: AS SHOWN	SHEET OF 11 13	DRAWING NO. 22-0747-UT-152	REV: A
--------------------	-------------------	-------------------------------	-----------

P:\2022\22-0747\00-CAD\FILESDWG\GENERAL\22-0747-UT-152.DWG - DATE: 2023-06-07